

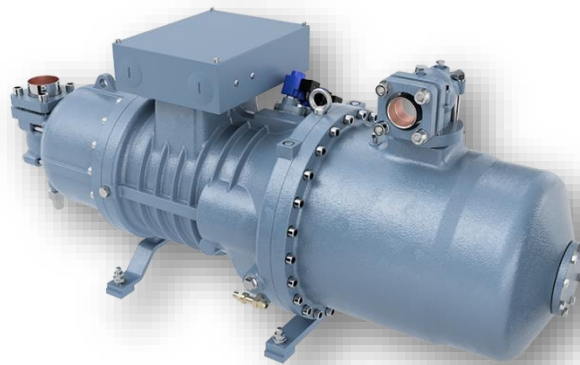





# User and Maintenance Manual RS3



MUM006 rev. 01  
EN (translation from IT)

	Summary	
<b>1</b>	 <b>Safety instructions</b> .....	<b>5</b>
1.1	 Importance of the manual .....	5
1.2	Responsibility limitations .....	5
1.3	 Symbols on the manual.....	6
1.4	 Safety signals .....	7
1.5	Machine switched-off status.....	7
1.6	Responsibilities of the operator .....	7
1.7	Misuse.....	8
1.8	Copyright.....	8
1.9	 Declaration of Incorporation .....	8
<b>2</b>	<b>General</b> .....	<b>10</b>
2.1	Identification .....	10
2.2	Intended Use .....	10
2.3	Directives and Standards Reference .....	11
2.4	Residual risks.....	11
2.5	Identification of dangerous areas.....	12
2.6	Introduction.....	13
2.7	The compression process.....	14
2.8	The rotors .....	15
2.9	The built-in volumetric ratio .....	15
<b>3</b>	<b>Lubrication</b> .....	<b>17</b>
3.1	Oil circuit.....	17
3.2	Oil flow-rate.....	18
3.3	Lubricants .....	18
3.4	Oil separation.....	19
3.5	Oil filter.....	20
3.6	Oil heater .....	21
3.7	Oil level.....	23
3.8	Lubrication monitoring .....	24
3.8.1	Oil temperature monitoring .....	24
3.8.2	Static pressure control .....	24
3.8.3	Flow control. ....	26
<b>4</b>	<b>Capacity control</b> .....	<b>27</b>
4.1	Operating principle and oil control circuit .....	27
4.1.1	Layout and identification of solenoid valves .....	28
4.2	STEP capacity control.....	29
4.2.1	Minimum capacity step (compressor step for start up and stop).....	29

4.2.2	50% CAPACITY .....	30
4.2.3	75% CAPACITY .....	30
4.2.4	100% CAPACITY .....	31
4.2.5	Control sequence: step configuration .....	31
4.3	Infinity capacity control: STEPLESS .....	33
4.3.1	Control sequence: stepless configuration.....	33
4.4	Variable speed control .....	35
4.5	Procedure for starting and stopping the compressor .....	37
4.6	Operating limits at part load .....	38
<b>5</b>	<b>Components .....</b>	<b>39</b>
5.1	Suction filter (standard) .....	39
5.2	Safety valve (standard) .....	40
5.3	Check valve (standard) .....	40
5.4	Rubber vibration damper (standard) .....	41
5.5	Oil flow switch (optional) .....	43
<b>6</b>	<b>Electrical motor .....</b>	<b>47</b>
6.1	General .....	47
6.2	Protection devices.....	49
6.2.1	Motor thermistors (standard) .....	49
6.2.2	INT 69 B2.....	50
6.2.3	INT 69 SNY (optional) .....	52
6.2.4	Lubricant/Discharge temperature probe (optional).....	55
6.3	Power supply.....	56
6.4	Selection of electrical components .....	57
<b>7</b>	<b>Data .....</b>	<b>58</b>
7.1	Electrical data .....	58
7.2	Technical data.....	60
<b>8</b>	<b>Dimensional drawings and packaging .....</b>	<b>61</b>
8.1	Dimensional drawings.....	61
<b>9</b>	<b>Transport, Handling and Storage .....</b>	<b>68</b>
9.1	Receiving and unpacking .....	68
9.2	Package dimensions:.....	68
9.3	Transport & Handling.....	69
9.4	Compressor lifting.....	70
<b>10</b>	<b>Performance data for the RS3 series compressors .....</b>	<b>71</b>
<b>11</b>	<b>Application range .....</b>	<b>72</b>
11.1	General .....	72
<b>12</b>	<b>Additional cooling .....</b>	<b>73</b>
12.1	Admissible compressor discharge temperature .....	73
12.2	Evaluating the additional cooling capacity .....	73
12.3	Injection of liquid by thermostatic expansion valve.....	74
12.4	Oil cooling via external heat exchanger .....	76

12.5	Position of the oil inlet-outlet connections .....	78
12.5.1	RS3-H100/110/120, H270/300/350/390, L080/090/100, L220/240/270/300 .....	78
12.5.2	RS3-H040/050/060, L060/070 .....	80
12.5.3	RS3-H070/080, L060/070.....	80
12.5.4	RS3-H140/160/180/200/220/240, L110/120/140/160/180/200 .....	81
<b>13</b>	<b>Operative instruction.....</b>	<b>82</b>
13.1	Ambient operating and storage temperature .....	82
13.2	Suction superheat .....	82
13.3	Pressure specifications .....	82
13.4	Balanced pressure when starting .....	82
13.5	Maximum ambient temperature .....	82
13.6	Number of start-ups .....	83
13.7	Starting, stopping and minimum running time .....	83
13.8	Installation.....	83
13.9	Heat pumps.....	84
13.10	Testing .....	84
13.10.1	Leak testing/evacuation/oil charge .....	84
13.10.2	Refrigerant charge.....	85
13.11	Starting.....	85
13.12	Protection devices intervention and trouble shooting.....	87
<b>14</b>	<b>Maintenance.....</b>	<b>88</b>
14.1	Lubricants .....	88
14.2	Bearings.....	88
14.3	Rotors rotation direction .....	88
14.4	Maintenance plan.....	88
<b>15</b>	<b>Capacity control conversion.....</b>	<b>89</b>
15.1	RS3-H040÷080, H140÷240, L030÷070, L110÷200 .....	89
15.1.1	Conversion from STEP (L4) to INFINITE (LZ) capacity control.....	89
15.1.2	Conversion from INFINITE (LZ) to STEP (L4) capacity control.....	92
15.2	RS3-H100/110/120, H270, L080/090/100, L220.....	95
15.3	RS3-H300/350/390, L240/270/300.....	97
<b>16</b>	<b>Extent of delivery.....</b>	<b>99</b>

# 1 Safety instructions

## 1.1 Importance of the manual

This manual contains the description of the operation and the necessary instructions to properly execute the main operations of use, ordinary and periodic maintenance of the compressor.

A prerequisite to ensure safe working conditions is compliance with all safety warnings and all instructions contained herein.



It must also ensure compliance with the local safety regulations currently in force in the installation location of the compressor as well as the general safety regulations. The information contained herein is intended for professional users who must have specific knowledge of how to use the compressor, must be authorized, trained and properly instructed.



We recommend the use of original parts and accessories.

The non-original parts will invalidate the warranty and may also be dangerous, reducing the life and performance of the compressor.



This manual, in case of transfer or sale, must always be delivered with the compressor. If it becomes lost or damaged, you have to ask for a copy to the manufacturer of the compressor or to the previous owner.

**The manual is considered an integral part of the system.**

## 1.2 Responsibility limitations

All indications and warnings given in this manual have been prepared taking into account the rules and regulations in force, the current state of the art of the technology and the skills and knowledge acquired.

The manufacturer assumes no responsibility for any damage caused by:

- failure to follow instructions contained in this user manual;
- usage outside of the intended purposes;
- use of non-specialized personnel;
- unauthorized modifications;
- technical changes;
- use of non-original spare parts and wearing parts.

If special versions has been requested, additional options have been ordered or technical updates have been applied, it is possible that the components actually supplied are changed with respect to the descriptions and illustrations in this manual.

The obligations agreed in the supply contract, the general terms and conditions and the conditions of supply of the manufacturer and the legal provisions in force at the time of signing the contract are intended as valid.

### 1.3 Symbols on the manual

The following **symbols** are used in this manual to get your attention how they should behave in all operating situations:



**RECOMMENDATIONS:** contains advice and recommendations as well as useful information for safe and trouble-free operations.



**CAUTION!:** indicates a potentially hazardous situation which, if neglected, can lead to material damages.

Carefully follow the instructions and work carefully to avoid accidents, injuries and material damages.



The warnings are accompanied by signal words that identify the severity of the danger.

**ADVICE!:** indicates a potentially hazardous situation which, if neglected, may cause minor or moderate injury.

**WARNING!:** indicates a potentially hazardous situation which, if left untreated, can cause death or serious injury.

**RISK!:** indicates a situation of imminent danger that, if left untreated, can cause serious injury or death. Carefully follow the instructions and work carefully to avoid accidents, injuries and material damages.



**MECHANICAL OPERATOR:** the indicated steps must be carried out by specialized mechanical operator that operates respecting the rules of national security and any specific rules of the workplace.



**ELECTRICAL OPERATOR:** the indicated steps must be performed by a specialized electrical operator that operates in compliance with the safety regulations concerning energized equipment.



**MAINTENANCE OPERATOR:** the indicated steps must be carried out exclusively by the operator in charge of the maintenance of the machinery. As such he has to:

- integrally read and understood the contents of this manual;
- operate respecting the rules of national security and any specific rules of the workplace.



**HANDLING OPERATOR:** the indicated steps must be carried out exclusively by the operator enabled to handle loads that operates respecting the rules of national security and any specific rules of the workplace.



**COMPANY SAFETY MANAGER:** the company responsible for safety must be informed of any residual risks present in the machine and has to take care of any application to local safety regulations or specific of workplace and environment.

## 1.4 Safety signals

On the compressor are affixed pictograms that identify any dangerous areas



**It is mandatory of the operator to keep in perfect status and replace them when they are no longer legible.**



**DANGER - VOLTAGE:** indicates hazardous situations due to electrical voltage. In case of failure to follow safety instructions, there is a risk of serious injury or death.



**DANGER - HIGH TEMPERATURE:** indicates hazardous situations due to compressor parts at high temperature. In case of failure to follow safety instructions, there is a risk of minor injuries and burns.



**DANGER - RISK OF EXPLOSION:** indicates hazardous situations due to objects in pressure and the possible intervention of the safety valves. In case of failure to follow safety instructions, there is a risk of serious injury or death.



**DANGER - CRUSHING:** indicates hazardous situations due to parts of the compressor under rotation. In case of failure to follow safety instructions, there is a risk of serious injury.



**DANGER - MOVING PARTS:** indicates hazardous situations due to parts of the compressor under rotation. In case of failure to follow safety instructions, there is a risk of serious injury.



**DANGER - EXPLOSIVE AREA:** indicates hazardous situations due to possibility of flammable or explosive area. In case of failure to follow safety instructions, there is a risk of serious injury and death.

**The area has to be protected from effective source of ignition.**

Tab. 1 Pictograms

## 1.5 Machine switched-off status

Defines the condition of safety of the machine, to be applied before any maintenance and/or adjustment operations.



It provides for the compulsory execution of the following steps:

1. Turning off the machine using the stop button.
2. Rotation of the main switch of the compressor to position 0 and padlocked.
3. Main switch turned to position OFF or 0.
4. When performing maintenance work indoors, switch on the room ventilation.
5. Close the valves of the compressor.
6. Use a 2 stage vacuum pump with gas ballast (1.5mbar standing vacuum) for gas recovery.



## 1.6 Responsibilities of the operator

The operator of the machine where the compressors is installed is therefore subject to the legal obligations concerning safety in the workplace.

In particular, the operator must:



- identify, through a risk assessment, the possible dangers arising from particular working conditions existing at the place of use of the compressor and of the machine.

- The user commits to comply with the applicable safety standards and regulations as well as with the guidelines given by this technical information.
- Designers, installers and service personnel must have a certified qualification for dealing with flammable refrigerants.
- The user must provide the operating personnel with all the necessary information on the applicable safety regulations.
- Ensure that all employees who use the machine have read and understood the user manual. Also instruct regularly the personnel on how to use the machine and inform them of the possible dangers;
- implement, through operating instructions, the behavioral requirements necessary for the operation of the compressor at the place of use;
- establish clear responsibilities for installation, operation, maintenance and cleaning of the compressor;
- check regularly, for all duration of use of the compressor, if the operating instructions correspond to the current version of the regulations;
- adjust, if necessary, the operating instructions to the new rules, regulations and conditions of use.

## 1.7 Misuse

Below are listed the actions required in order to prevent improper use of the compressor:

- Use the compressor only if it is in perfect technical condition. Promptly repair faults that can compromise security.
- It is not permitted to make changes to the compressor that may compromise its security of the same.
- Disconnect the power supply before performing regular maintenance, cleaning and repair work and ensure that it is an impossible compressor against restarting (disconnect the controls).
- Do not by-pass the safety devices or put them out of order.
- All operations on the compressor and/or on electrical equipment must be carried out by specialized personnel.
- Repairs and maintenance operations must be carried out only when the compressor is off. Make sure that it is impossible an accidental restarting of the machine!
- When performing operations on the compressor, the compressor must not be under pressure. Close the compressor or system valves and recover the gas into the compressor and pipings. Observe the indication of the pressure gauge!
- The protective devices of the starter must be removed only when the machine is turned off and must be reassembled correctly at the end of the operations. Remove the touch guard only when the machine and the pressure line have cooled down.
- The provisions relating to environmental protection require that all fluids handled during the maintenance operations (eg. Oil) are collected and disposed in accordance with current regulations.

## 1.8 Copyright

The content, texts, drawings, pictures and any other representation are protected by copyright and trade mark rights. Any violation is punishable.

It is forbidden the reproduction, even partial and by any means, and the use and/or disclosure of the content without prior written declaration by the manufacturer.

## 1.9 Declaration of Incorporation

The following is an example of the conformity declaration and the information contained in it.





As the compressor are dedicated to be installed in a refrigeration system, the CE assessment and certificate have to be produced by the designer and manufacturer of the system.  
The original document is delivered in soft copy upon requirement.

<b>SRMTEC</b>			
<b>Dichiarazione di incorporazione</b>	<b>Declaration of Incorporation</b>	<b>Déclaration de l'incorporation</b>	
Ai sensi dell'allegato II, parte 1, sezione B della Direttiva Macchine 2006/42/CE.	As per EC Machines Directive 2006/42/EC, attachment II, part 1, section B.	En vertu de l'annexe II, part 1, section B de la Directive Machines 2006/42/CE.	
Il fabbricante: <b>Refcomp Italy Srl</b> Largo Municipio, 34 - 39044 Egna - Bolzano - ITALY	The manufacturer: <b>Refcomp Italy Srl</b> Largo Municipio, 34 - 39044 Egna - Bolzano - ITALY	Le fabricant: <b>Refcomp Italy Srl</b> Largo Municipio, 34 - 39044 Egna - Bolzano - ITALY	
Con la presente dichiara che le seguenti Quasi-Macchine:	Hereby declare that the following new partly-completed machines:	Par la présente déclare que les nouvelles Quasi-Machines suivantes:	
<b>Moto-compressori semiermetici a vite per condizionamento e refrigerazione :</b>	<b>Semi-hermetic screw compressors for refrigeration and air-conditioning applications:</b>	<b>Moto-compresseurs semi-hermétiques à vis pour la réfrigération et le conditionnement d'air:</b>	
PSS-118-040	PSP-2H-075	PSP-2L-0175	
PSS-150-050	PSP-2H-110	PSP-2L-0210	
PSS-175-070	PSP-2H-0245	PSP-2L-0245	
PSS-210-070	PSP-2H-0280	PSP-2L-0280	
PSS-210-080	PSP-4H-0647	PSP-4L-0647	
PSS-280-080	PSP-4H-0750	PSP-4L-0750	
PSS-318-110	PSP-4H-0861	PSP-4L-0861	
PSS-341-120	PSP-4H-1029	PSP-4L-1029	
PSS-410-140	PSP-4HF-0350	PSP-4LF-350	
PSS-415-160	PSP-4HF-0420	PSP-4LF-420	
PSS-510-180	PSP-4HF-0490	PSP-4LF-490	
PSS-562-200	PSP-4HF-0560	PSP-4LF-560	
PSS-700-220	PSP-4HN-350	PSP-4LN-350	
PSS-700-240	PSP-4HN-420	PSP-4LN-420	
PSS-860-270	PSP-4HN-490	PSP-4LN-490	
PSS-910-300	PSP-4HN-560	PSP-4LN-560	
PSS-1000-350	PSP-6H-1125	PSP-6L-1125	
PSS-1100-390	PSP-6H-1291	PSP-6L-1291	
	PSP-6H-1544	PSP-6L-1544	

## 2 General

### 2.1 Identification

The SRMTec RS3 series screw compressors are helical twin screw oil-injected compressors (Fig. 2 shows an example with all the main parts and assemblies) specifically designed to operate with HFC refrigerants and to be installed in refrigeration system.

This compressor range can also be applied with HCFC or HFO refrigerants.

The identification of the compressor model is possible by the following scheme:

	<b>RS3-</b>	<b>H</b>	<b>140-</b>	<b>L</b>	<b>4</b>	<b>H</b>
RS3-	= Refrigerant Screw Compressor					
H	= Motor size L = small motor size; H = large motor size.					
140	= Nominal power [Hp]					
L	= Accessories voltage L = Electrical accessories 220V AC 50/60Hz; M = Electrical accessories 110V AC 50/60Hz; Y = Electrical accessories 24V AC 50/60Hz; U = Electrical accessories UL approved 220V AC 50/60Hz (only for S series); V = Electrical accessories UL approved 110V AC 50/60Hz (only for S series)					
4	= Partial load control (0/4/Z) 0 = without steps capacity control; 4 = 4 steps capacity control (100-75-50% - minimum step) made with 3 solenoid valves, only for S series; Z = Infinite capacity control (from minimum capacity to 100% or from 50 to 100%), only for S series;					
H	= High compression ratio version (if required)					

### 2.2 Intended Use

The **RS3 semi-hermetic rotary screw compressors** have been designed and manufactured exclusively for the installation into a complete system and for the compression of clean refrigerants.

The use of A2L class refrigerants with semi-hermetic compressors in so-called "closed plants" is subjected to the safety regulations on flammable substances according to ATEX 2014/34/EU regulation.



The electrical system is designed for use in non explosive and non flammable ambient; the usage in ambient with Category II and Zone identification 2 (rare and short term danger) is possible only with proper instructions to be followed.

**VENTING SYSTEM ACCORDING TO EN 50014 MUST BE PROVIDED TO PREVENT FORMATION OF EXPLOSIVE MIXTURE IN CASE OF A LEAK (MUST BE SWITCHED ON IN CASE OF INDOOR MAINTENANCE WORK)**

Any whatsoever claim for damages resulting from misuse is excluded. The designer and the operator of the machine where compressor is installed are solely responsible for any damage resulting from misuse.



**THE COMPRESSOR USAGE FOR SCOPES DIFFERENT AND NOT INCLUDED IN THE INDICATED EXCLUDES THE MANUFACTURER FROM ANY RESPONSIBILITY FOR THE RISKS THAT SHOULD BE CAUSED AND FOR ANY DAMAGES TO THE MACHINE, PEOPLE OR THINGS.**



**NEVER APPLY THE COMPRESSOR IN ZONE 1 OR 0 AREAS OR APPLICATIONS OR AMBIENT CATEGORY "I".**

## 2.3 Directives and Standards Reference

The compressor in question has been designed and manufactured taking into account the feedback that emerged from a careful analysis of risks and tending to achieve, given the state of the art, the objectives set by the essential requirements of safety and health provided by European Directives.

In the Tab. 2 are listed the referenced European Directives and Standards (EN):

Directive	Description
2006/42/EC	"Machinery Directive on the approximation of the laws of the Member States relating to machinery".
2014/35/EC	"Low Voltage Directive on the approximation of the laws of the Member States relating to electrical equipment designed for use within certain voltage limits".
2014/30/EU	"Electromagnetic Compatibility Directive on the approximation of the laws of the Member States relating to electromagnetic compatibility".
EN 1012-1	"Compressors and vacuum pumps. Safety requirements. compressors".
EN 12693:2008	"Refrigerating systems and heat pumps - Safety and environmental requirements - Positive displacement refrigerant compressors"
EN 60204-1	"Safety regulations concerning basic electrical equipment of machines".

Tab. 2 Reference standards and directives

## 2.4 Residual risks

We inform the authorized operators that, despite the manufacturer has adopted all the measures possible to make the construction of the compressor sure, remain potential residual risks described in Tab. 3.

Residual risk n° 1	DANGER OF BEING EXPOSED TO FLAMMABLE AND EXPLOSIVE GASSES
Frequency of exposure	Low and accidental. There may be exposure if the required ventilation system is not working properly.
Extent of the damage	Serious lesions (non reversible) and even death.
Solutions adopted	Respect of the correct procedure for maintenance operation. Safety signal.

Tab. 3 Residual risk n° 1

Residual risk n° 2	DANGER OF BEING AFFECTED BY GAS PRESSURE
Frequency of exposure	Low and accidental. There may be exposure if the operator decides to perform voluntarily impropriety, prohibited and not reasonably foreseeable.
Extent of the damage	Serious lesions (non reversible).
Solutions adopted	Respect of the correct procedure for maintenance operation. Safety signal.

Tab. 4 Residual risk n° 2

## 2.5 Identification of dangerous areas

Dangerous areas of the compressor are identified in the following images.



These areas have to be considered into the risk assessment of the machine were the compressor is installed and appropriate precautions must be taken to reduce residual risks (see chapter 2.4)

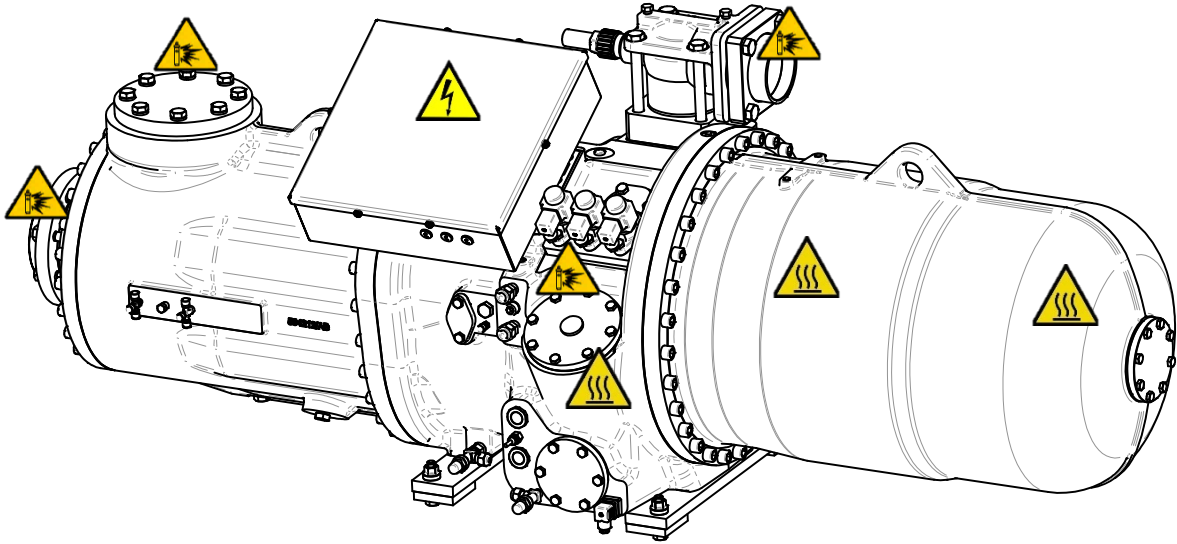

Fig. 1 Dangerous area identification

## 2.6 Introduction

The compressors feature a semi-hermetic construction, and are fitted with a three-phase asynchronous two-pole motor (2900 rpm at 50 Hz) directly coupled to the male rotor, which in turn drives the female rotor. These compressors are fitted out with a high-efficiency oil separator, whose position is different depending on the series (see chapter 3: "Lubrication") and that allows the compressors to be installed in the refrigerant circuit without requiring any additional components. The motor is cooled by the intake gas that flows through special holes and grooves.

For the RS3 series the capacity control is achieved by using a slide valve, which is moved by a hydraulic piston and which ensures part load operation by controlling the suction volume.

The compactness, low noise, efficiency, completeness of the ranges and their simple installation make these series compressors ideal for the construction of a range of high-efficiency and modern water/water and air/water chillers and heat pumps.

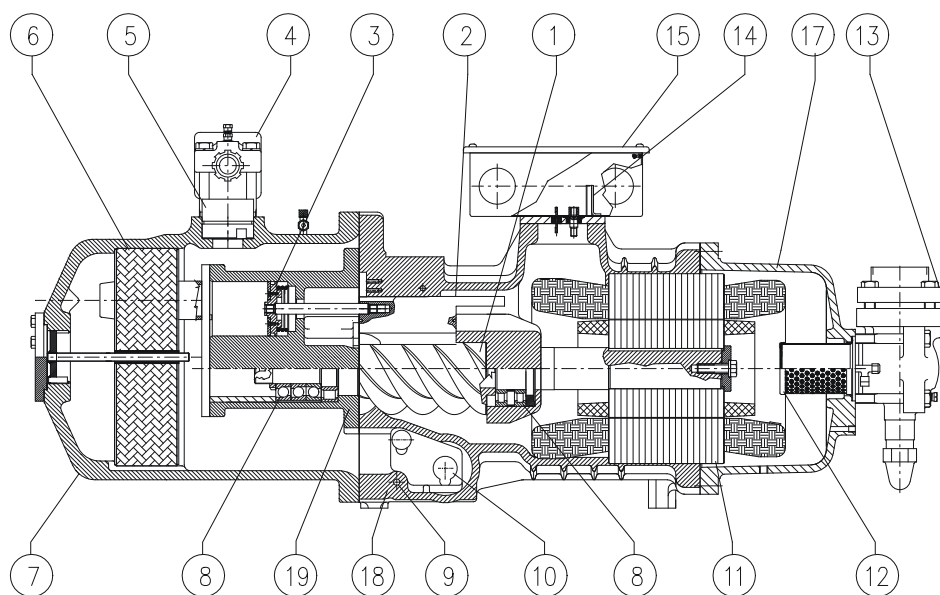

- |  |  |
|--|--|
| 1. Rotors;   | 10. Oil filter;                        |
| 2. Slide valve for capacity control (only for RS3 series); | 11. Electrical motor;                  |
| 3. Slide valve control piston (only for RS3 series);       | 12. Suction filter;                    |
| 4. Discharge shut off valve;                               | 13. Suction shut off valve;            |
| 5. Check valve;  | 14. Motor protection device;           |
| 6. Oil separator "Demister";                               | 15. Terminal box;                      |
| 7. Oil reservoir/separator;                                | 16. Suction bell;                      |
| 8. Rolling bearings;                                       | 17. Rotor housing;                     |
| 9. Crankcase heater;                                       | 18. Bearings housing (discharge side). |

Fig. 2: Schematic drawing of an RS3 series compact screw compressor

## 2.7 The compression process

The rotors are housed inside horizontal cylindrical chambers, fitted with a suction port (on the electric motor side) and a discharge port (on the oil separator side). Tightness against leakage through the extremely reduced clearance between the rotors and the chambers is guaranteed by a film of oil that is injected directly onto the screw profile.

The compression process essentially involves the following three phases (for reasons of clarity, the following description is limited to one lobe on the male rotor and one flute on the female rotor):

- **Suction**

With reference to Fig. 3, when the lobe on the male rotor is unmeshed from the flute on the female rotor, the suction port opens into the compression chamber and, due to the rotation of the screws, the suction volume increases, creating negative pressure that draws in the refrigerant fluid. The suction phase ends when, due to rotation, the suction port is closed.

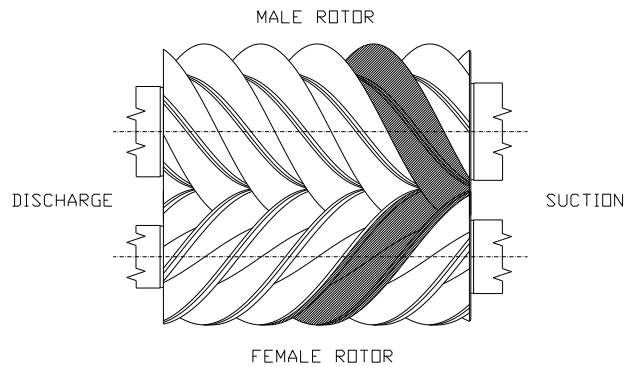

Fig. 3: chamber at the end of the suction phase

- **Compression**

With reference to Fig. 4, as rotation continues in the compression chamber, both the suction and the discharge ports are closed, the volume inside the chamber progressively decreases and the trapped gas moves in the longitudinal direction of the rotors, towards the discharge port. In other words, the trapped gas is compressed.

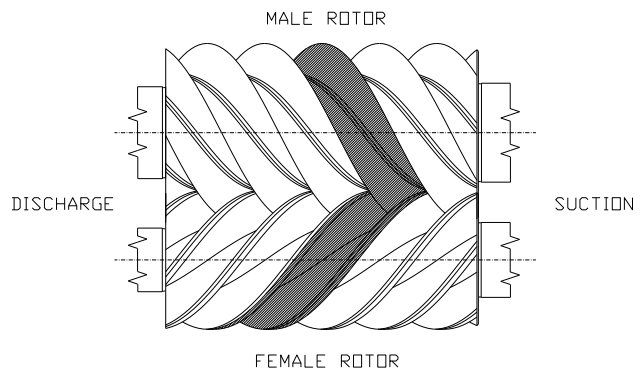

Fig. 4: chamber during the compression phase;

- **Discharge**

With reference to Fig. 5, the rotation continues until the discharge port opens and the compressed gas is completely expelled, due to the progressive intermeshing of the lobe and the flute. As the gear ratio is 5/6 (5 lobes on the male rotor and 6 flutes on the female rotor) and the rotation speed is around 3000 rpm at 50Hz (asynchronous motor), each minute there will be  $3000 \times 5 = 15000$  discharge cycles, which means an almost complete absence of pulsation at the discharge. A reciprocating compressor operating at 1500 rpm would require 10 cylinders to achieve the same result.

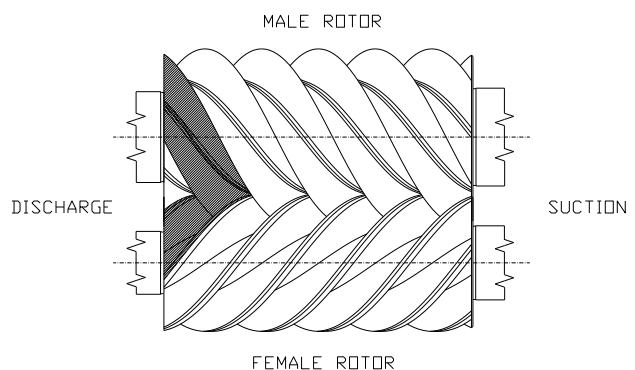

Fig. 5: chamber at the start of the discharge phase;

## 2.8 The rotors

The rotors, see Fig. 6, have an asymmetrical shape with 5 lobes and 6 flutes, and are made entirely by SRMTec. The perfect intermeshing between the suitably lubricated rotors ensures extremely smooth and silent compressor operation. The picture shows also the correct directions of rotation.

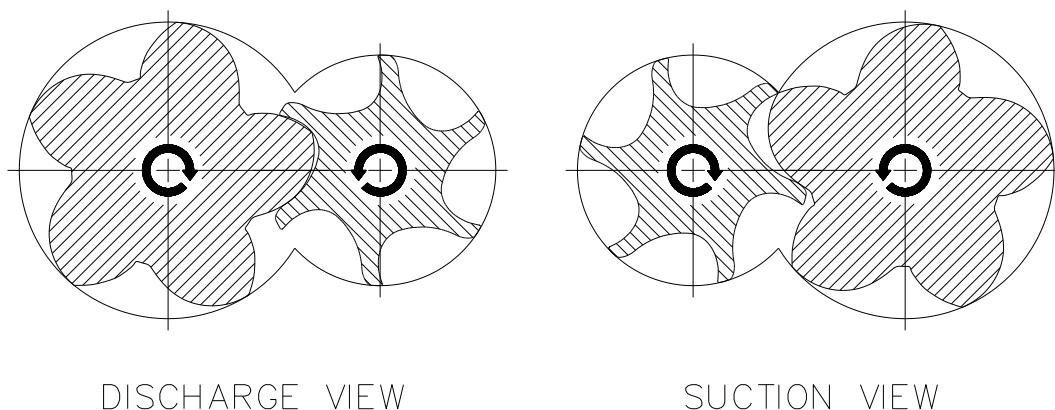
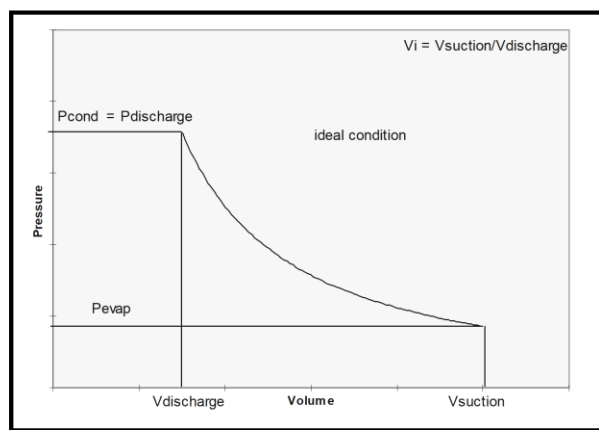

Fig. 6: view of the rotors and correct direction of rotation;

## 2.9 The built-in volumetric ratio

The size and the shape of the discharge port determine the value of the so-called “ $V_i$ ”: the “built in volumetric ratio”, defined as the ratio between the volume of the gas at the start and the end of the compression process. This ratio does not depend on the operating conditions, but rather corresponds, according to the type of refrigerant gas, to a precise compression ratio between the compressor discharge pressure and suction pressure. When this compression ratio coincides with the ratio between the condensing pressure and the evaporation pressure, the compression process is running at maximum efficiency. Indeed, the gas discharged from the compression chamber is at the same pressure of the compressor outlet (condensing pressure) and the work required to compress the gas is minimum. When, on the other hand, the pressure at the outlet differs from the discharge pressure of the gas from the rotors, there is over compression or under compression (instantaneous when the discharge port opens), which means a waste of energy, see Fig. 7.

Therefore, the choice of the most appropriate “ $V_i$ ” ratio to suit the application ensures that energy wastage can be avoided or at least minimized.



### **Ideal compression process:**

condensing pressure = rotor discharge pressure;

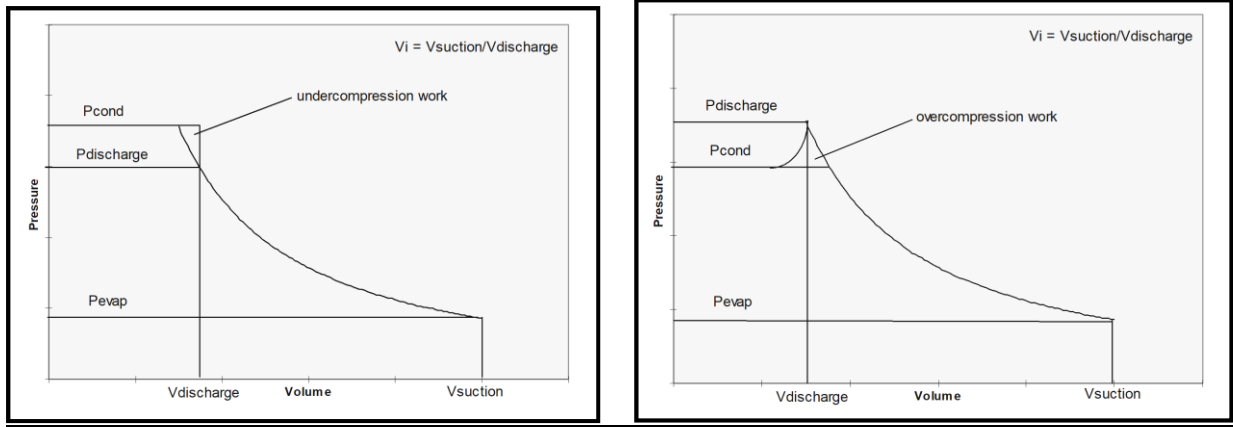

Fig. 7: the compression process on the p-V diagram;

As standard, SRMTec uses a  $V_i$  ratio in the RS3 series compressors that is optimized for water/water or water/air chiller applications, featuring low compression ratios. Consequently, to maximize the compression efficiency in special applications with high pressure ratios (tropicalized chillers, heat pumps), the RS3 series compressors are also available with higher " $V_i$ " ratios.

The RS3 series compressors thus have the following built-in volumetric ratio:

- ✓  $V_i = 2.2$ : "W" version models;
- ✓  $V_i = 2.6$ : standard models;
- ✓  $V_i = 3.2$ : "H" version models;
- ✓  $V_i = 4.4$ : "R" version models

The following diagrams show the recommended fields of application for the two built-in volumetric ratios ( $V_i$ ) of the RS3 series. These fields are expressed according to the condensing and evaporating temperatures of the specific used refrigerant:

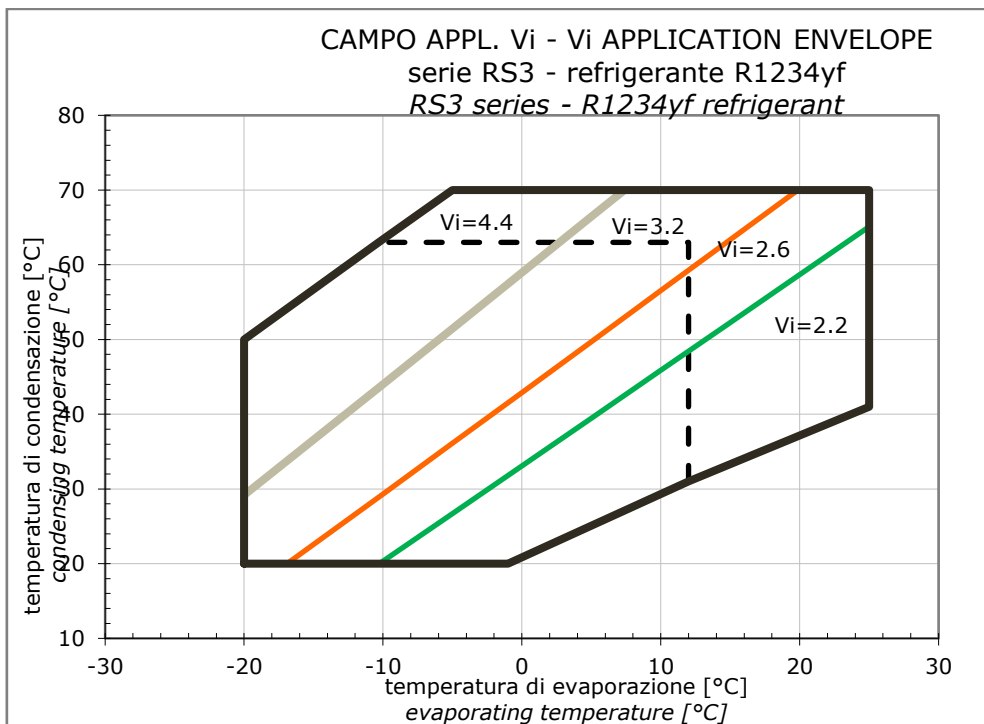

Fig. 8:  $V_i$  values recommended with R1234yf

Please contact SRMTec for more indications regarding the suggested compression ratio ( $V_i$ ) according to operating conditions.



### 3 Lubrication

#### 3.1 Oil circuit

The oil carries out the following functions:

- ✓ Dynamic seal between the rotors and the cylindrical chambers;
- ✓ Lubrication of the bearings and the rotors;
- ✓ Control of the slide valve for capacity control (only for the RS3 series);
- ✓ Cooling.

Illustrative examples of the RS3 series internal oil circuits are those shown in the cross sections of the following pictures.

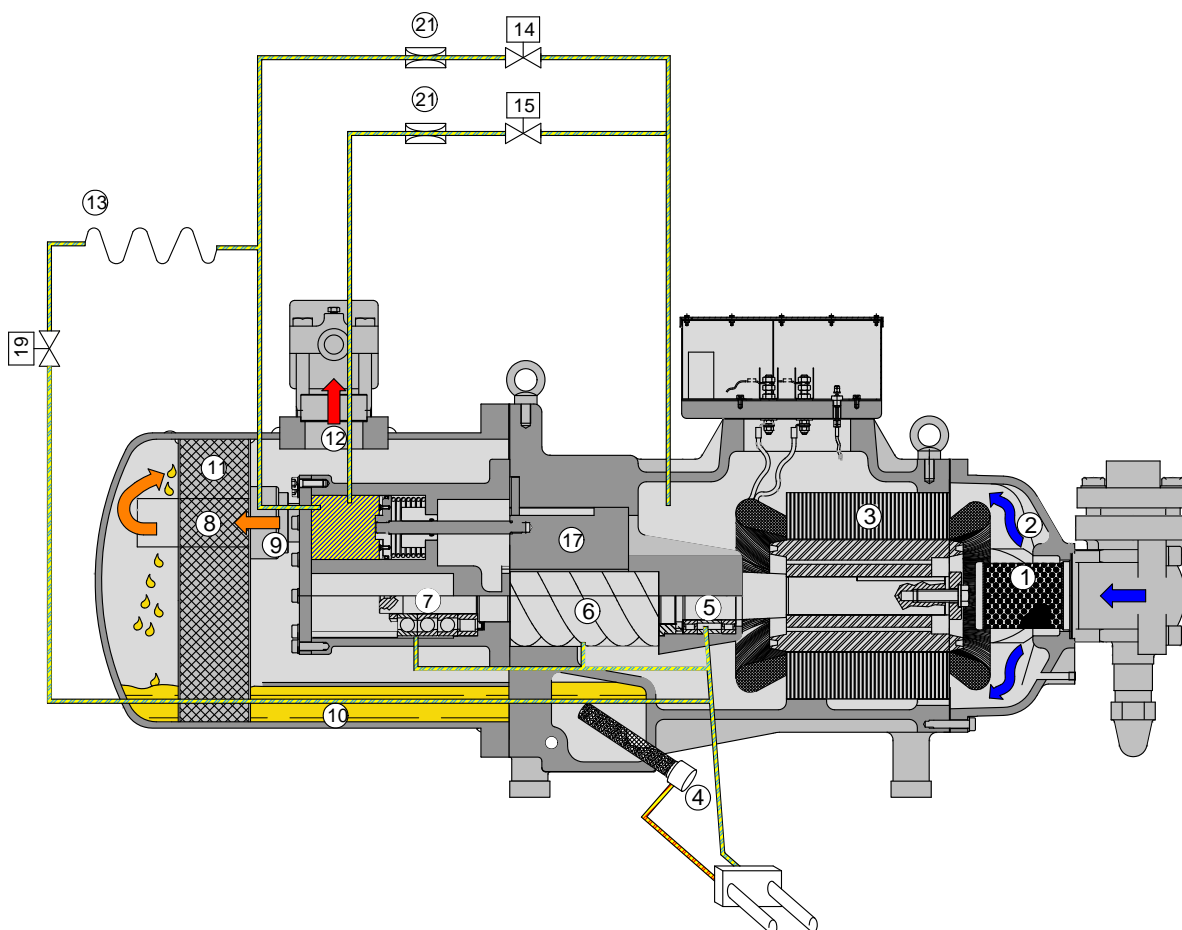

Fig. 9: diagram of the internal oil circuit for lubrication and operation of the slide valve;

4	oil filter	13	capillary tube
5, 7	rolling bearings	14, 15, 16	Unloading solenoid valves for capacity control
6	Rotors	17	slide valve and actuator piston for capacity control
11	oil separator 'DEMISTER'	18	oil inlet-outlet connection for the external cooling circuit
		19	Loading solenoid valve for capacity control (if present)

The lubricant is held in the bottom of the housing and in the oil separator. As shown in Fig. 9, the oil separator of the RS3 compressors is connected directly to the front of the compressor flanged casing.



#### Warning!

The oil contained in the sump is at the discharge pressure (high pressure).

The oil is circulated by exploiting the pressure difference between the crankcase, at the discharge pressure, and the point of injection, where the pressure is slightly higher than the suction pressure (no oil pump is then necessary).

From the crankcase the oil flows through a filter to the suction bearings, to the injection point on the screw profile and to the discharge bearing chamber. For the RS3 compressors only, there is also a capillary tube that carries the oil to the slide valve control cylinder for capacity control.

Then the oil leaving the slide valve control cylinder -whenever present-, the suction bearings and the discharge bearing chamber flows to the suction side of the rotors and it is compressed through the rotors together with the suction gas.

The high-pressure oil-gas mixture undergoes to a separation process in the 'DEMISTER', part (11) in Fig. 9 (see paragraph 3.4 'Oil separation'); then the oil is collected at the bottom of the oil separator while the gas leaves the compressor through the discharge shut-off valve located on top of the oil separator.

Downstream the oil filter are two connections (oil outlet/inlet) for the connection to an external cooling system, which could be required by the operating conditions (see chapter 12 "Additional cooling").

### 3.2 Oil flow-rate

As the circulation of oil is generated by a pressure difference, the oil flow rate depends upon the difference between the discharge and suction pressure, according to the following equation:

$$V_{OILIO} = K \cdot \sqrt{P_S - P_A}$$

Where:

- $V_{oil}$  volumetric oil flow-rate through the filter [l/min]
- $K$  = coefficient, depending on the model of compressor (see Table 1)
- $P_S$  = discharge pressure [bar]
- $P_A$  = suction pressure [bar]

RS3	H040 L030	H050 L040	H060 L050	H070 L060	H080 L070	H100 L080	H110 L090	H120 L100	H140 L120	H160 L140	H180 L150	H200 L160	H220 L180	H240 L200	H270 L220	H300 L240	H350 L270	H390 L300
K	5,5		6		6,75						7,5							

Table 1: coefficients K for calculating the oil flow-rate;

The minimum oil flow rate required to fulfil all the purposes (lubrication, seal, slide valve control and cooling) is ensured when the compressor works within the established field of operation, as long as the oil filter is normally clean and the oil maintains its characteristics.

During the starting phase, as the pressures are always balanced in the compressor, there is no oil circulation; however, the bearings and rotors are designed to tolerate a few seconds of dry operation before the necessary pressure difference is reached.



**Warning!**

Within 20 seconds from starting, the compressor has to work within the recommended application range (minimum pressure difference, see paragraph 0).

In part-load operation and, in general, when the minimum pressure difference is not easily reached, special measures may need to be adopted, such as:

- ✓ delayed start of the condenser fans, on air-cooled units;
- ✓ the use of a water flow-rate control valve on water-cooled units;
- ✓ the use of a pressure regulating valve between the compressor and the condenser (contact SRMTec for further information). At the same time, it might be also necessary to keep the time of the compressor part-load operation to the minimum (about 5 seconds).

### 3.3 Lubricants

The lubricants have been selected mainly based on the following requirements:

- ✓ Seal against leaks along the rotor profile;

- ✓ Correct lubrication of the bearings;
- ✓ Good viscosity characteristics at high temperature;
- ✓ Good miscibility with the refrigerant fluid at low temperature.



### Warning!

Do not use lubricants other than those recommended. All the oils approved by SRMTec must not come into contact with the humidity in the air.

Depending on the kind of refrigerant fluid, below are the oils recommended by SRMTec for the RS3 series compressors.

Supplier	Type	Chemical comp.	Density at 15°C [g/ml]	Viscosity at 40°C [cSt]	Flash point [°C]	Pour point [°C]	Flock point [°C]
CPI	Solest 170 (BS 170)	POE	0.95	175.2	265	-30	None
Emkarate	RL170H <sup>1</sup>	POE	0.968	170	290	-25	None
FUCHS	Reniso Triton SE 170 <sup>2</sup>	POE	0.98	170	260	-24	None
UNIQEMA	<u>Icematic</u> SW220	POE	0.98	220	280	-22	None

Table 2: properties of oil for HFC refrigerants

Supplier	Type	Chemical comp.	Density at 15°C [g/ml]	Viscosity at 40°C [cSt]	Flash point [°C]	Pour point [°C]	Flock point [°C]
CPI	CP-4214-320	complex ester <del>complex</del> ester	1.05	298	271	-35	<del>None</del> none

Table 3: properties of oil for HCFC refrigerants (R22)

## 3.4 Oil separation

The separation of the oil is required for the following reasons:

- ✓ to ensure the accumulation of oil in the compressor crankcase so that it can continuously be delivered to the bearings and the rotors;
- ✓ to prevent the migration of oil from the compressor into the refrigerant circuit.

SRMTec has developed a high efficiency oil separator with low space requirements.

The presence of the oil separator could affect the compressor sound emissions, however this is already particularly low because of the thickness and shape of SRMTec compressor design.

The oil is separated thanks to:

- ✓ the impact with the inside surface of the oil separator;
- ✓ the difference in specific mass between the oil and the gas;
- ✓ actual filtering of the discharged gas by the "DEMISTER" (part (7) and (11) respectively in Fig. 9; variation in direction and speed of the compressed refrigerant-oil mixture).

Fig. 10 points out the specific position of the oil separator both for the RS3 series while picture 2-D shows the schematic cross-section of a RS3 compressor, highlighting the separation process through the oil separator.

<sup>1</sup> Standard for RS3 compressors

<sup>2</sup> Approved alternative lubricant

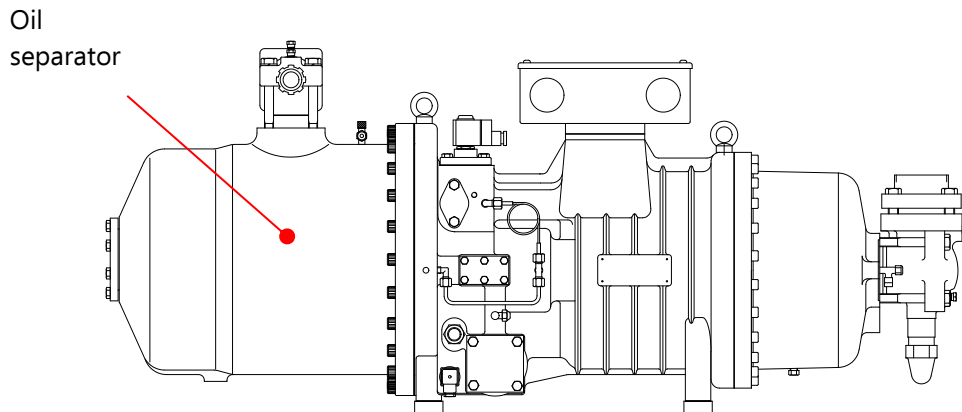

Fig. 10: specific position of the oil separator both for the RS3 series;

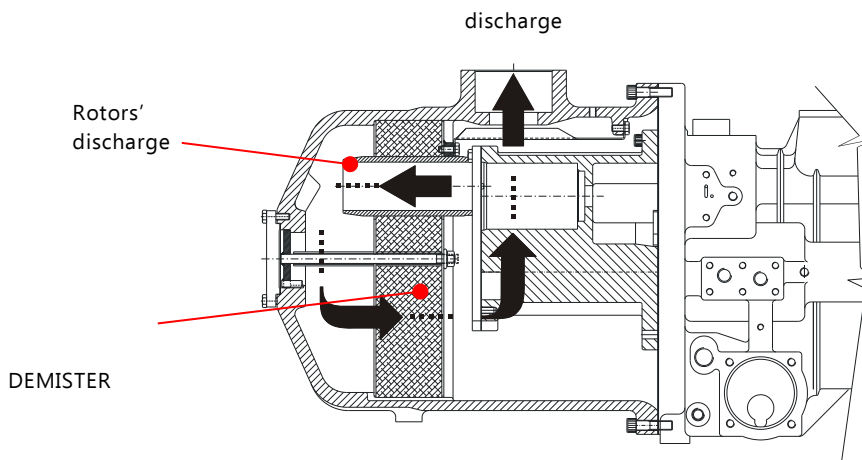

Fig. 11: separation process of the oil-refrigerant mixture using the 'DEMISTER' separator in the RS3 series compressors; The high-pressure oil/gas mixture leaving the rotors is subjected to an initial separation due to the different velocity between the gas and oil droplets; further separation comes from the impact of the mixture against the inside wall of the sump, where the oil droplets are collected and slide to the bottom; finally the mixture is subjected to the main separation process by flowing through the "DEMISTER" filter, where the oil droplets continuously change their velocity and direction. The oil that is separated from the refrigerant then accumulates at the bottom of the separator.

The lower the refrigerant mass flow rate, the higher the oil separation efficiency. Under the most critical conditions the oil carry-over rate is less than 2% of the refrigerant mass leaving the compressor.

### 3.5 Oil filter

The compressors are fitted with a high efficiency oil filter. In models RS3-H040÷060/L030÷050 this is positioned inside the compressor, and therefore to be inspected the discharge bell and the oil separator need to be removed. In the remaining models of the RS3 series, on the other hand, the oil filter is positioned on the bottom of the crankcase, as shown in Fig. 9<sup>3</sup>, and as a result it is easily accessible from the outside of the compressor. For further details on the position, see chapter 8: "*Dimensional drawings and packaging*".

The oil filter must always be clean to ensure correct lubrication. The cleanness condition of the filter can be checked by the pressure drop through the filter itself. Under normal conditions and with a new filter the pressure drop is lower than 0.8 bar.

When first starting the compressor, the oil filter may become clogged quite quickly if the refrigerant circuit has not been carefully cleaned.

<sup>3</sup> This is simply a schematic drawing; refer to the dimensional drawing for each individual compressor to identify the actual position of the high and low pressure fittings and the oil filter.

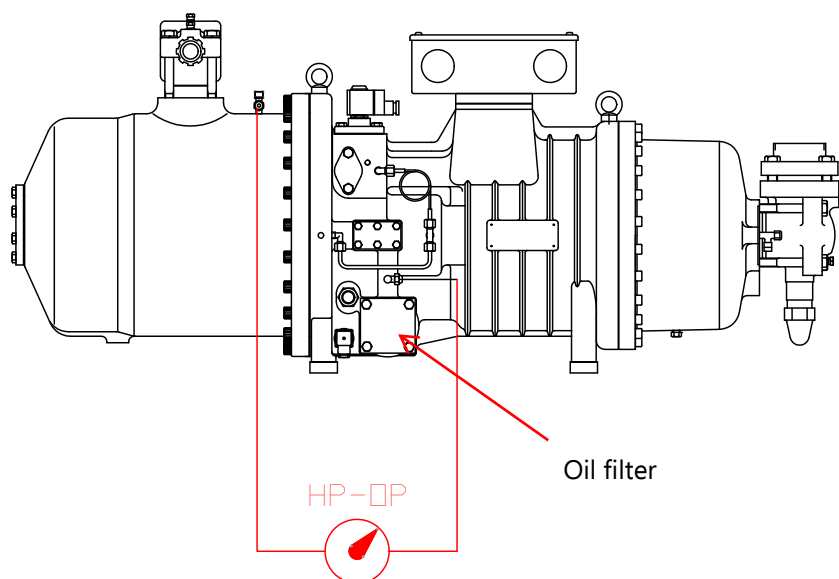

Fig. 12: position of the oil filter in the RS3 series compressors (in models H040÷060/L030÷050 the filter is located inside the oil separator) and definition of the HP-OP pressure drop across the filter

Considering HP as the high pressure -discharge side- and OP the pressure of the oil leaving the filter, the pressure difference **HP-OP** represents the pressure drop across the filter.



### Warning!

For the limit value of the pressure drop HP-OP across the oil filter at which the filter needs to be replaced, see paragraph 0: "lubrication monitoring".

When the pressure drop across the filter exceeds the values indicated in paragraph 0, the filter is dirty and must be replaced. The compressors are fitted with a fine mesh oil filter: in some cases, then, the filter may even need to be replaced after just a few hours of operation, and in any case when the pressure drop exceeds the values shown in the above-mentioned paragraph (consequently, a spare filter should be ordered together with the compressor).

## 3.6 Oil heater



### Warning!

The application of the oil heater is permitted only in Zone 2 areas.

**Danger of spark formation due to unintended switching operation or overheating of the crankcase oil heater during oil change.**



### Caution!

Due to the high oil solubility by the refrigerants, an oil sump heater is absolutely required. Switch on the oil heater during standstill operations.

The oil heater is designed to prevent the excessive dilution of refrigerant in the oil when in standstill, and must be on when the compressor is off. The heater is a tubular heating element, see Fig. 14.

The socket where the oil heater is inserted could be in the shape of a sleeve or a hole machined directly in the housing. Refer to Table 4 for details and position related to specific model.

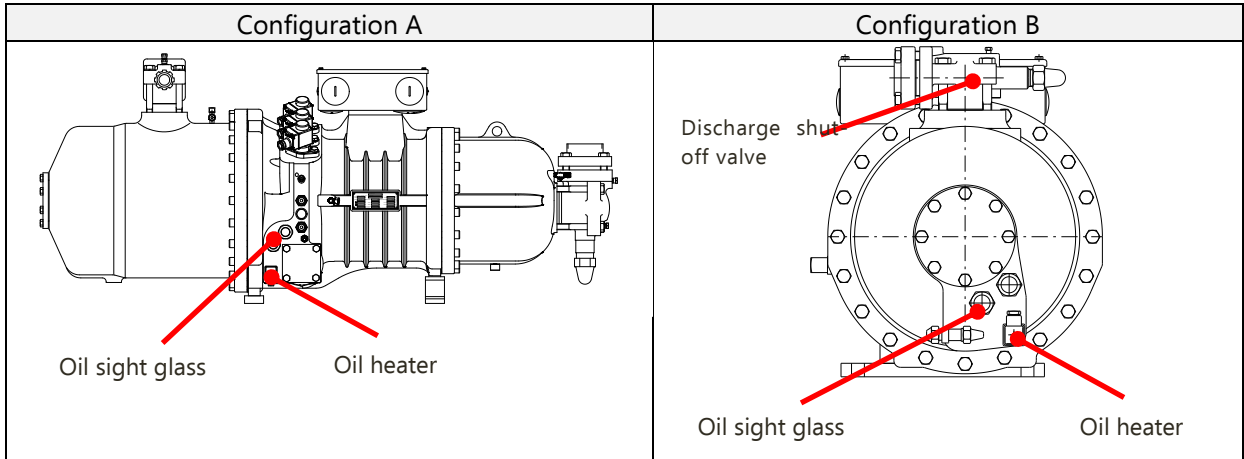

Fig. 13: positions of the oil heater and sight glass

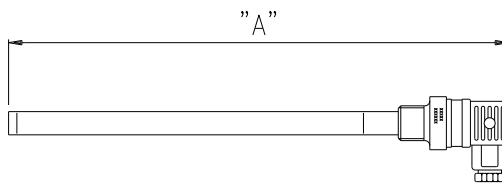

Fig. 14: Oil heater dimensions

The characteristics of the crankcase heater are reported on tables below:

RS3	H040	H050	H060	H070	H080	H100	H110	H120
	L030	L040	L050	L060	L070	L080	L090	L100
Configuration (ref. Fig. 13)	B		A		A			
No. of sight glasses	2		1		2			
Socket shape	Hole				Sleeve			
Length "A" (ref. Fig. 14)	248				302			
Nominal power [W]	200							
Voltage supply [V-Hz]	220-50/60**							
Tightening torque [Nm]	30							

RS3	H160	H180	H200	H220	H240	H270	H300	H350	H390	H160
	L140	L150	L160	L180	L200	L220	L240	L270	L300	L140
Configuration (ref. Fig. 13)	A									
No. of sight glasses	1					2				
Heater socket shape	Hole									
Heater length "A" (ref. Fig. 14)	302									
Nominal power [W]	275									
Voltage supply [V-Hz]	220-50/60**									
Tightening torque [Nm]	30									

Table 4: oil heater and sight glass configuration

\*\* : other voltages on request (110V-50/60Hz, 24V-50/60Hz)

The oil heater must be used when the compressor is off, and in the following situations:

- ✓ when the compressor is installed outdoors (if necessary, the oil separator should be insulated);
- ✓ extended standstill periods;
- ✓ high refrigerant charge;
- ✓ risk of the refrigerant condensing inside the compressor. During standstill the compressor crankcase must have the highest temperature in the entire refrigerant circuit.



**Warning!**

Before starting up for the working season, the heater must be on for at least 24 hours before starting the compressor.

### 3.7 Oil level

The oil, if requested, is always supplied in separate cans inside the packaging, to prevent contamination of the plant with any external part or air content. The standard oil charge is indicated in the table of technical data reported in chapter 7.2: "*Designation of the model and technical specifications*".



**Warning!**

The compressor is delivered with a nitrogen charge of about 1 bar to prevent contamination of external air.

It is responsibility if the customer to extract the nitrogen charge of the compressor, produce a deep vacuum and charge the oil amount required.

The oil level can be checked through one or two sight glasses according to the model type (for the position on the compressor, see Fig. 13): for the models with 2 sight glasses, the upper one indicates the optimum level for the correct operation of the compressor, while the lower one indicates the minimum level, below the which the compressor cannot operate.

For the number and position of the sight glass/es please refer to Table 4 and Fig. 13

During operation a certain quantity of oil may migrate into the refrigerant circuit. Moreover for the RS3 compressors a variation in the load entails also a variation in the amount of oil contained in the hydraulic cylinder which control the slide valve; consequently there may be fluctuations in the oil level due to its flowing from and to the slide valve control cylinder. In any case, during operation the level of oil must remain visible within the sight glass.

These sight glasses also show if there is too much refrigerant diluted in the oil. In fact, this problem is highlighted by the continuous presence of foam and is caused by an excessive cooling of the oil when the additional cooling is obtained by the liquid injection (see chapter 12: "*Additional cooling*").



**Warning!**

- ✓ According to the type of installation and the operating conditions of the compressor (whether the oil cooling circuit is used or not, see chapter 12: '*Additional cooling*'), some extra oil may be needed.
- ✓ The oil level in the sight glass should be checked when the compressor is on.

## 3.8 Lubrication monitoring

### 3.8.1 Oil temperature monitoring

Normally the lubrication can be indirectly monitored by checking the discharge temperature of the oil: lack of lubrication leads to an increase of that value.

Hence a temperature sensor is available (optional with the INT 69 B2 module, standard with INT 69 SNY module), to monitor the oil temperature (see chapter SA-05: '*Electrical devices*').

Whenever this accessory is not used, a safety thermostat should be installed on the discharge pipe to switch off the compressor as the temperature reaches 120°C.



#### Warning!

The additional cooling of the oil (chapter 12) does not guarantee the indirect monitoring of the lubrication through the oil temperature value.

Depending on the operating conditions, however, the discharge temperature may be quite different from the alarm condition of the above-mentioned device (120°C).

Consequently, the delay in the increase and in reaching the critical temperature of 120°C, corresponding to insufficient lubrication, must be considered, as the correct operation of the compressor may be affected in this period.

As a result, SRMTEC suggests further alternative methods for monitoring correct lubrication, described below.

### 3.8.2 Static pressure control

The correct circulation of the oil is guaranteed by the fact that both the filter is clean and the compressor operates in the admissible field of operation (see chapter SA-10: "*Application range*"; Fig. 16 shows an example).

With reference to Fig. 15<sup>4</sup> and Fig. 16, to protect the compressor against insufficient lubrication, the following three pressure values need to be measured:

- ✓ The high pressure "HP";
- ✓ The oil pressure "OP";
- ✓ The low pressure "LP";

and make sure that:

- ✓ The compressor works inside the application range, within 20 sec. from the starting;
- ✓  $HP - OP < 3,5$  bar, if the compressor works outside the area A3.
- ✓  $HP - OP < 1,5$  bar, if the compressor works inside area A3.



#### Warning!



- Only IP54 or higher protection class oil pressure switches are allowed.
- The comply with the regulations required for Hazardous Zone 2 has to be conducted by the machine designer.

So the level of filter lodgement is not fixed but rather depends on the operating conditions of the compressor; that is, if working inside area A3, the filter will be considered dirty when the pressure drop across the filter is greater than 1.5 bar. Outside of area A3, on the other hand, but always within the application range, the filter will be considered dirty if the pressure drop exceeds the value of 3.5 bar.

<sup>4</sup> This is simply a schematic drawing; refer to the dimensional drawing for each individual compressor to identify the actual position of the pressure connections.



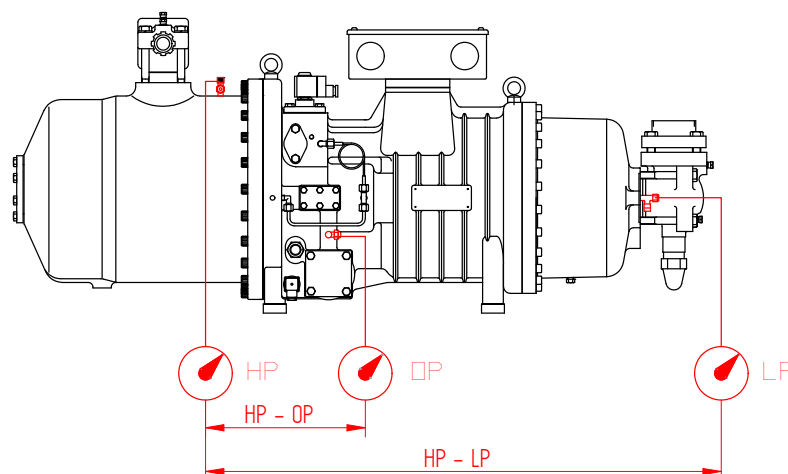

Fig. 15: measuring the HP, OP and LP pressure values in the RS3 series

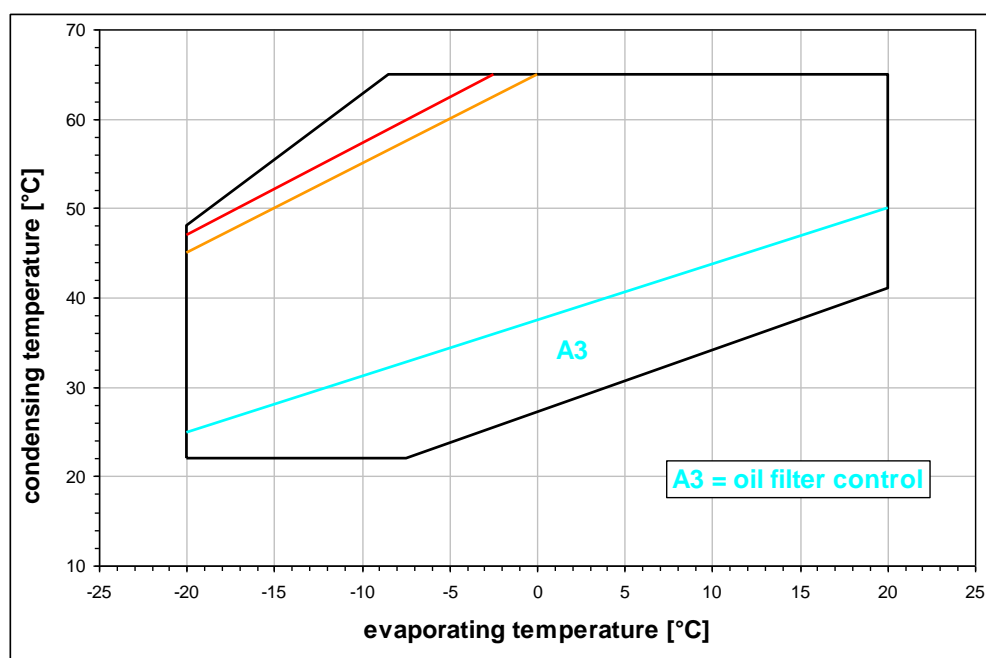

Fig. 16: generic application limit for series RS3 compressors



### Warning!

- ✓ The compressor cannot operate for more than 20 seconds outside of the conditions required by the application limits and with the oil filter dirty. After such time, the protection system have to be activated to stop the compressor;
- ✓ The differential pressure switch for monitoring the status of the oil filter must be suitable for high pressure.

### 3.8.3 Flow control.

The monitoring of oil flow through the compressor could be done with a flow switch kit (see chapter 5: *Components*)

This device is a dynamic type control cause, setting aside how much oil is in the crankcase, shows its effective flow inside the circuit made on the body of compressor. This circulation is granted only by the difference of pressure between discharge and suction line and is hindered by concentrated pressure drops as for instance the oil filter.

The oil flow switch with its inlet and outlet connections are assembled from the outside to the body of compressor by customer, according to his dimensional needs.

The electrical contact of oil flow switch is "open type" but the correct working condition is that, during the running of compressor, the oil flowing through it will close the electrical contact.

If will happen that the difference between discharge and suction pressure couldn't assure the flow of oil it is beard a delay of intervention of oil flow switch.

The statements recommended by SRMTec for this delay are:

- 120 seconds during start-up procedure;
- 60 seconds during normal working.

## 4 Capacity control

### 4.1 Operating principle and oil control circuit

The SRMTec screw compressors can operate both at full load and part load.

The cylindrical chambers that house the screw rotors are fitted with a longitudinal port, whose connection with the suction side is regulated by the position of the slide valve (17), see Fig. 17.

When the slide valve completely closes the above mentioned port, the effective compression length is maximum and coincides with the entire length of the rotors; when, on the other hand, the valve moves towards the discharge and the opening expands longitudinally, the effective working length of the rotors is reduced and as a consequence a smaller quantity of gas is processed. As a result, adjusting the volume taken in by the rotors make it possible to control the mass flow processed and definitely the cooling capacity generated by the compressor.

The slide valve is controlled by a hydraulic cylinder activated by the oil pressure.

In particular for the RS3 compressors the user can choose among two different types of partial load control:

- a) STEP or L4 configuration: the capacity is controlled into 4 fixed capacity steps (minimum-50-75 and 100% load).

The oil control circuit for the capacity control is characterized by three normally-closed solenoid valves: 14, 15 and 16.

- b) STEPLESS or LZ configuration: the capacity is controlled with continuous variation of the load, either from the minimum step to 100%, or from 50 to 100%.

The oil control circuit for the capacity control is characterized by three normally-closed solenoid valves: 14, 15 and 19.



The position and identification of the solenoid valve 16 and 19 could correspond in some models, even if the operation of the valve could differ.

Please refer to chapter 15 Capacity control conversion to identify the operation mode.

The following paragraphs describe the operating principle of the oil circuit in the step and stepless configurations and, as you can see, this principle is the same in both the RS3 series compressor types.

### 4.1.1 Layout and identification of solenoid valves

The following table identify the position and the function of the slide valve according to the different compressor models.

Further it is also identified the position of the slide valve in the compressor body.

Layout ID	Slide valve position	STEP Control Valves position	STEPLESS Control Valves Position
1	Top		
2	Bottom		
3	Side		

Table 5: solenoid valves and slide valve layout ID;

RS3	H040	H050	H060	H070	H080	H100	H110	H120	H140	H160	H180	H200	H220	H240	H270	H300	H350	H390			
	L030	L040	L050	L060	L070	L080	L090	L100	L120	L140	L150	L160	L180	L200	L220	L240	L270	L300			
Layout ref. Table 1	1			1			2			1			1			2			3		

Table 6: solenoid valves and slide valve layout correspondence

## 4.2 STEP capacity control

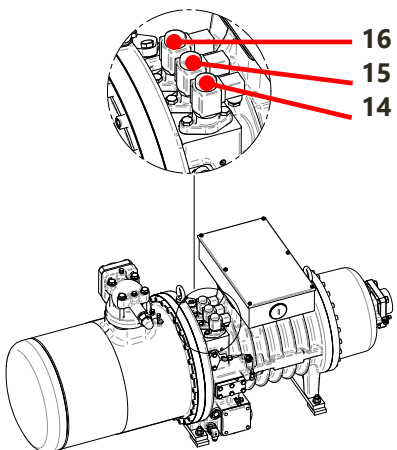
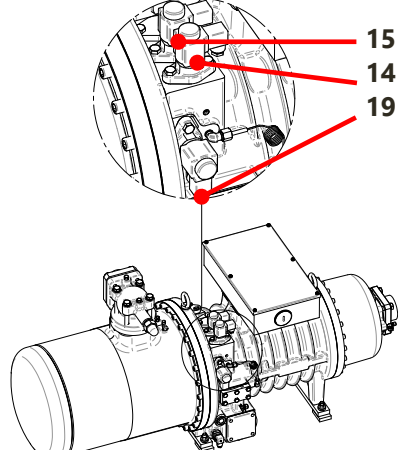
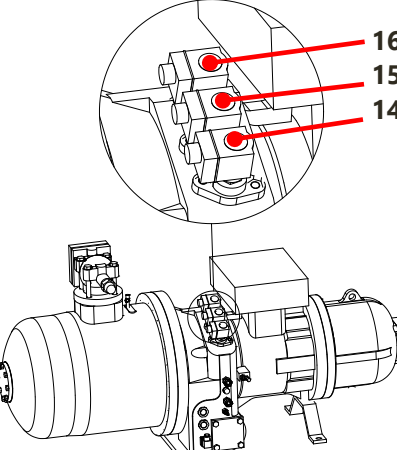
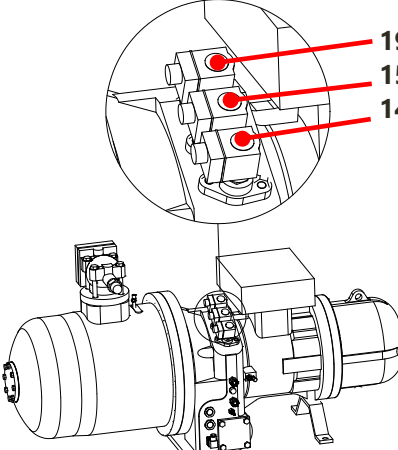
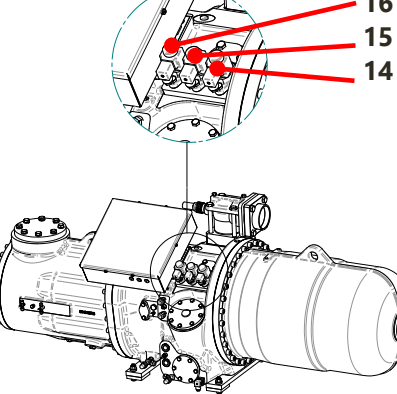
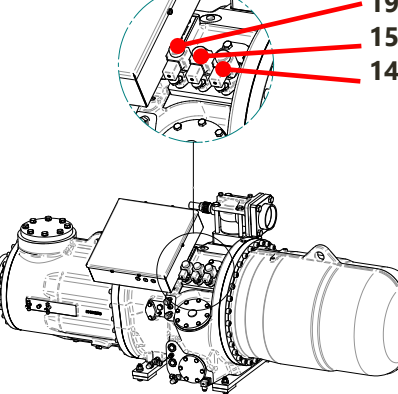
The slide valve is controlled by a hydraulic piston that can have four distinct positions, corresponding to the capacity steps: 100 - 75 - 50% - minimum step (note: the effective capacity steps may differ from the rated values, according to the normal operating conditions and from compressor to compressor).

As you can see from the picture, for all the compressors the oil circuit is characterized by the three normally-closed solenoid valves 14, 15 and 16 which respectively allow to control the three capacity steps: minimum capacity, 50 and 75%.

Below is a brief description of the operation of the oil circuit in the four compressor capacity steps.

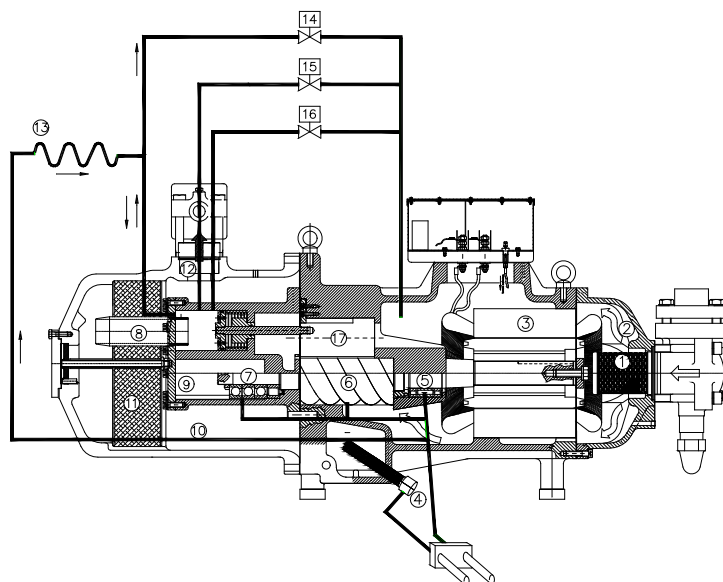

Fig. 17: step capacity control oil circuit

- 14, 15, 16: capacity control solenoid valves;
- 17: capacity control slide valve and operation piston;
- 13: capillary tube (external to the compressor);

### 4.2.1 Minimum capacity step (compressor step for start up and stop)

Fig. 18 shows how the oil runs inside the control circuit. At the minimum step the solenoid valve 14 is opened, while the valves 15 and 16 are closed. Therefore, the oil coming from the oil reservoir, flows through the opened port to the suction side, not pressurizing the control cylinder. Consequently, the piston is pushed to the end stroke, the longitudinal port is completely opened on the suction side and the length along which the rotors are working is the shortest.



#### Caution!

Concerning the step capacity control mode (4 steps), the minimum capacity step can be used only to start and stop the compressor; it cannot be used for continuous running operations.

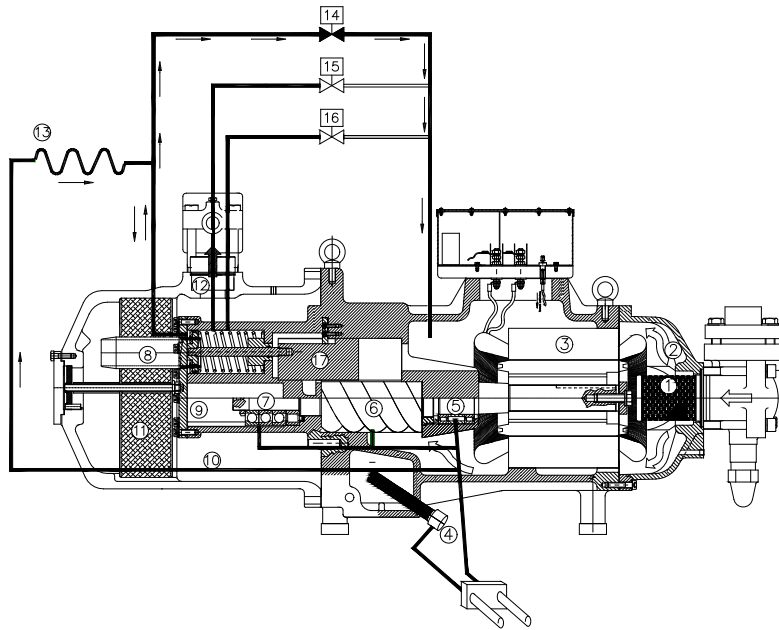

Fig. 18: Minimum capacity control oil circuit

#### 4.2.2 50% CAPACITY

With reference to Fig. 19 at 50% capacity, the solenoid valve 15 is open while the valves 16 and 14 are closed; the oil enters the cylinder (through the 1<sup>st</sup> hole on the left) and drives the piston to the position corresponding to the 2<sup>nd</sup> hole, where the oil flows to the suction side. The slide valve also moves and partially closes the longitudinal opening, thus increasing the effective working length of the rotors.

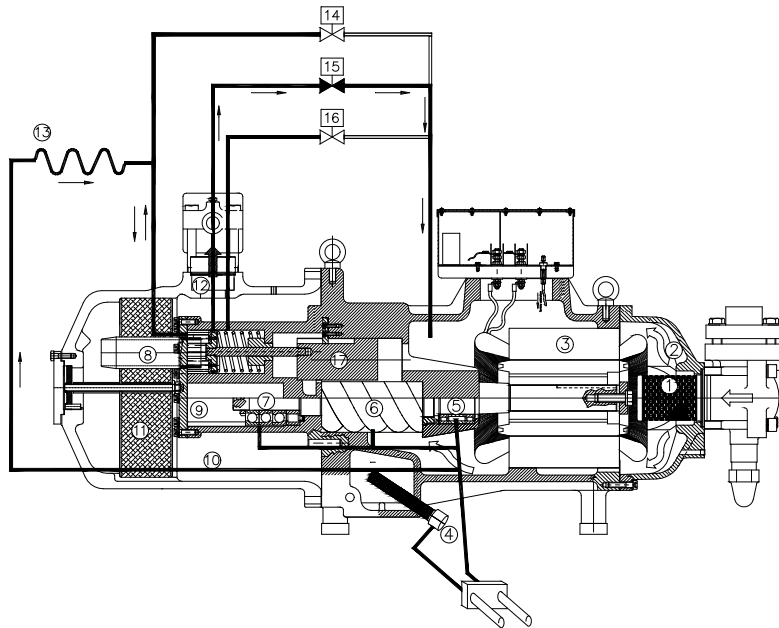

Fig. 19: capacity control at 50% step

#### 4.2.3 75% CAPACITY

At 75 % capacity, see pictures 3-G and 3-H, the situation is similar to the previous one, but now the solenoid valve 16 is open while the valves 15 and 14 are closed; the control piston is thus positioned corresponding to the 3<sup>rd</sup> hole, the slide valve closes the opening further and increases the working length of the rotors.

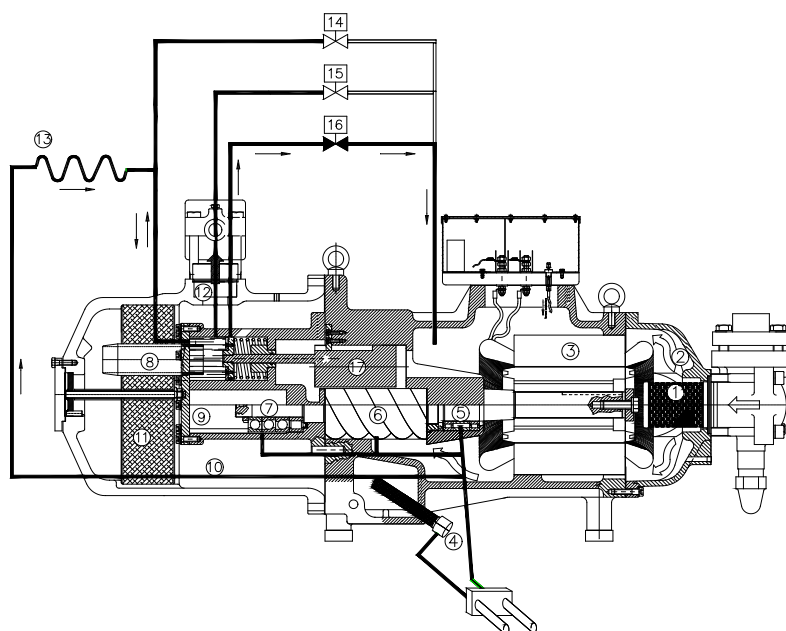

Fig. 20: capacity control at 75% step;

#### 4.2.4 100% CAPACITY

At 100% capacity, see Fig. 21, all the solenoid valves are closed; the oil can no longer leave the cylinder and pushes the piston to the limit on the right side and the slide valve completely closes the longitudinal opening, meaning that the compression occurs along the entire length of the rotors.

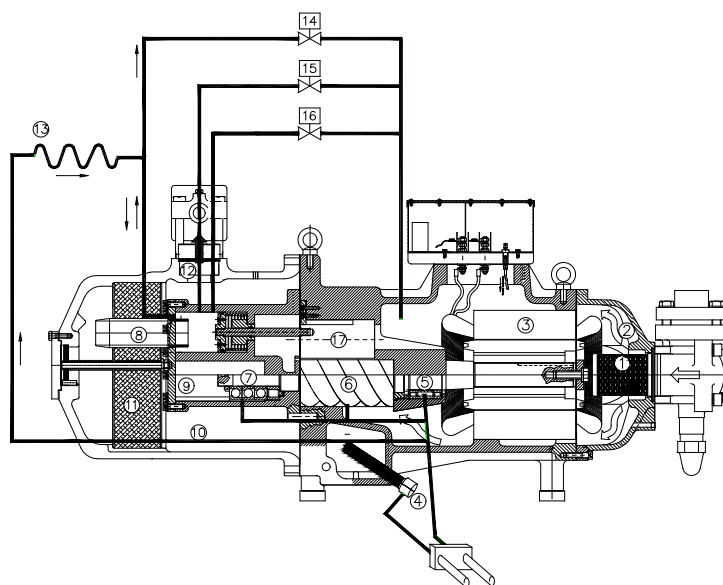
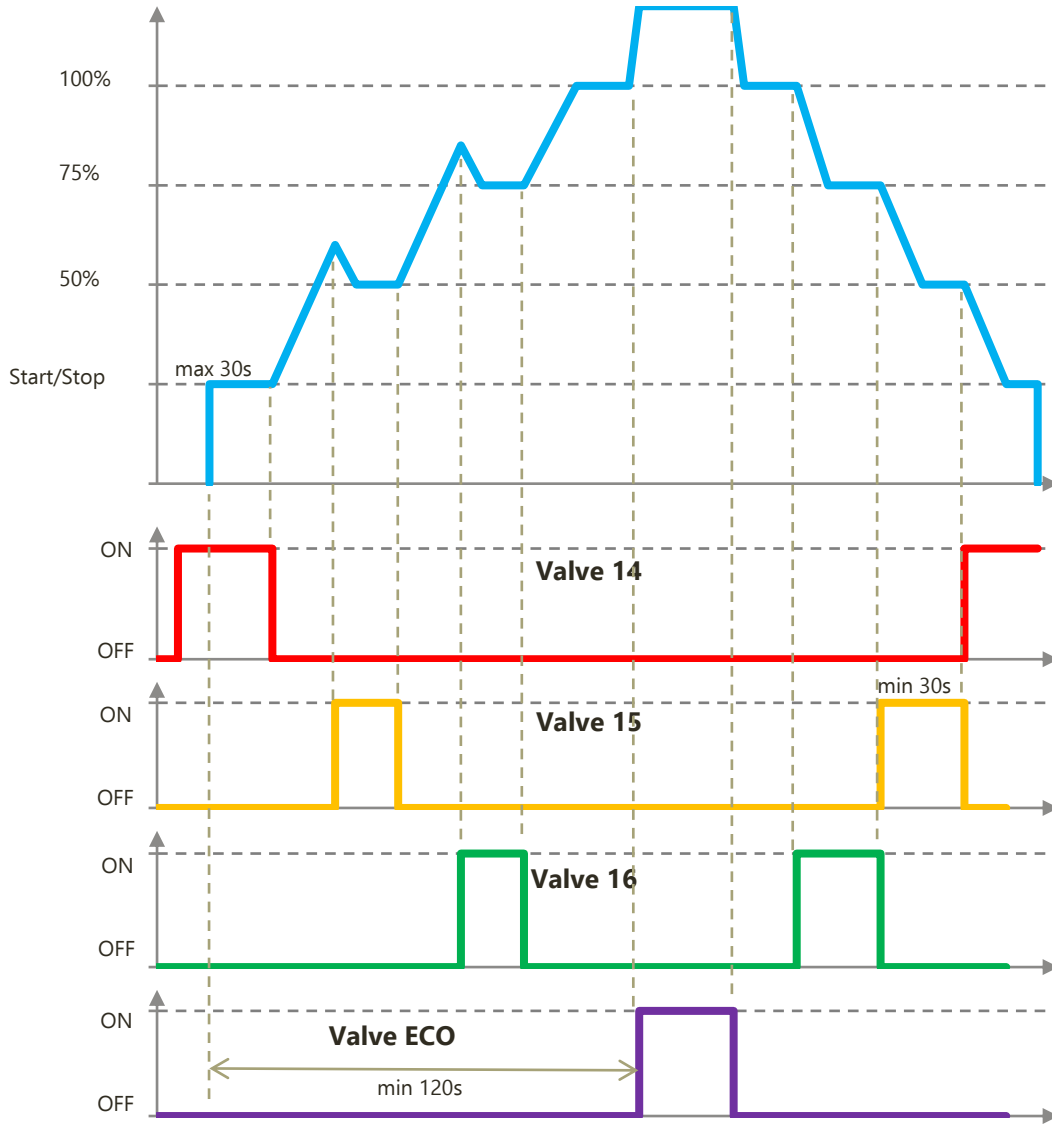

Fig. 21: capacity control at 100% step

#### 4.2.5 Control sequence: step configuration

The oil flow is controlled by the three solenoid valves, normally-closed, positioned on the compressor casing according to the layout defined in Table 6. For all the compressors series RS3 these valves are energized according to the logic shown in Table 7.

Load control graph



Load (capacity steps)	Solenoid valves		
	16	15	14
100%	Off	Off	Off
75%	On	Off	Off
50%	Off	On	Off
Minimum step (start up and stop)	Off	Off	On

"Off" = solenoid not energized;  
 "On" = solenoid energized;

Table 7: operating logic of the solenoid valves for step capacity control;



### 4.3 Infinity capacity control: STEPLESS

Infinite capacity control is recommended whenever the cooling capacity of the system has to be controlled with a high degree of precision, while it is not very useful in systems featuring high inertia, where step control is more suitable.

The cooling capacity is therefore controlled by using the normally-closed solenoid valves (14), (15) e (19) with the following logic:

- ✓ (19): fill the hydraulic cylinder for increasing the cooling capacity required by the users;
- ✓ (14), (15): empty the hydraulic cylinder, until the minimum step or 50%, to decrease the cooling capacity required by the users.

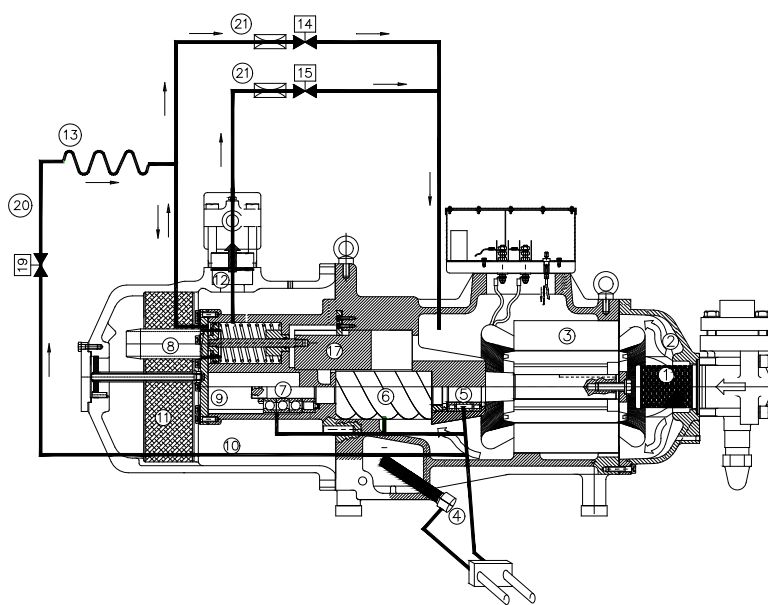

Fig. 22: infinite capacity control oil circuit (step less configuration)



The position and identification of the solenoid valve 16 and 19 could correspond in some models, even if the operation of the valve could differ. Please refer to chapter 15 to identify the operation mode.

This brings about continuous control of the flow processed by the compressor, from the minimum value to the maximum value. For details on how to convert the configuration from the step to stepless for all the compressors RS3, see chapter 15.

The oil channels must be throttled to achieve slower motion and more accurate positioning of the control piston. With reference to the Fig. 22, the load channel (20) can be throttled by installing a modified capillary tube or a reduced orifice (13). The unload channel (14) or (15) can be throttled by installing an orifice (21) upstream the solenoid valve.

Both items are supplied on request as they belong to the conversion kit from the configuration step to the stepless one, and have to be assembled by the user (see chapter 15 Capacity control conversion)

#### 4.3.1 Control sequence: stepless configuration

Cooling capacity control is obtained using solenoid valves (14),(15) and (19) which have to be excited according to logic control shown in Fig. 23 and Table 8.

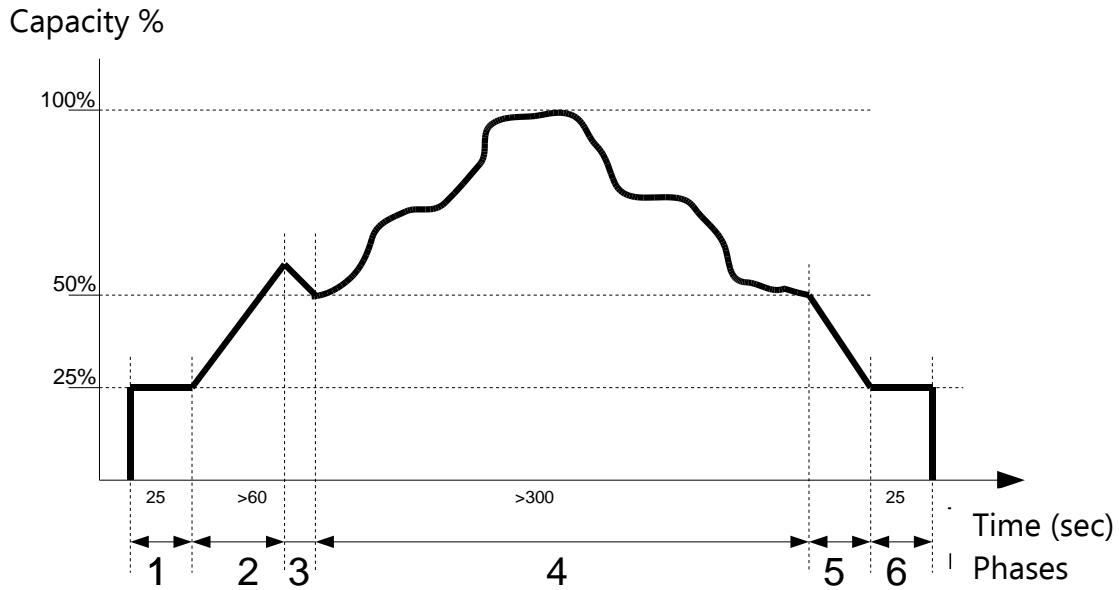

Fig. 23 Logic control of solenoid valves for stepless configuration

STEPLESS CONTROL 100÷50%				
Phase	Regolation	SOLENOID VALVE		
		14	15	16
1	Start-up	ON	OFF	OFF
2	Loading > 50%	OFF	OFF	ON
3	Unloading to 50 %	OFF	ON	OFF
4	Modulation	OFF	ON/OFF	ON/OFF
5	Unloading to 25%	ON	OFF	OFF
6	Stop	ON	OFF	OFF

“Off” = solenoid not excited

“On” = solenoid excited

Table 8: Control sequence of solenoid valves in stepless configuration

**Attention !**

The working at partial load condition is allowed according to the application limits reported in the chapter SA-10: “Application limit”.

Particularly, the compressor can work at the minimum capacity step only during the startup phase, the stop phase (see paragraph 3.3) and in any case for short period of time (see previous page).



At any rate the part load operation requires specific actions to prevent:

- ✓ The insufficient return of oil due to the reduced speed of the gas;
- ✓ Higher temperatures on the discharge side, caused by the compression lower efficiency and by the lower refrigerant mass flow;
- ✓ An overheating of the electrical motor that might occur whenever the tension value is out of the given range.

Thorough and extensive testing is recommended.

## 4.4 Variable speed control



### RECOMMENDATIONS:

Usage of frequency converter to control the load of the compressor and of the system could give significant advantage in system performances.

Usage of frequency converter in combination of compressor internal load control is discouraged.



### Warning!

**The installation of the inverter is permitted only in Safe Zone areas.**

**Danger of spark formation due to switching operation.**

**Use shielded cables between frequency converter and compressor motor**

The usage of a frequency converter permits the speed control with conventional asynchronous motors, reaching the highest efficiency control method for compressors.

In the variable-frequency control mode, the operating frequency of the motor can be adjusted automatically to greatly reduce the reactive loss of the motor.



All the SRMTec compressor are designed to operate in the frequency range 25Hz-60Hz, and the motor have to be connected according to the Fig. 24.

When using frequency converter for capacity control, several basic factor has to be taken into account:

- positive displacement compressors have a practically constant torque requirement over the entire speed range;
- to grant the constant torque operation of the compressor, the voltage and frequency must be changed proportionally;
- the speed of the asynchronous motor is affected by the slipping of the motor.

This mean that, as conventional inverters cannot supply motor overating voltages higher than supply voltage, when the motor is driven at frequency higher than the nominal speed (>50Hz) it will be supplied with "under voltage" conditions. The selection of a special winding motor voltage (380V-3-60Hz) could avoid this situation but the sizing of the inverter is affected by the larger current drawn.

For details on motor size and electrical data please refer to Table 15; for special motor voltage please check the data on SRMTec selection software or contact SRMTec.

When the driving frequency instead is much lower than the nominal, the refrigerant flow could be not sufficient to cool down the motor.

It is so necessary to check in the SRMTec selection software the application envelope limitations according to the rotating frequency.



### Caution!

**Due to the high oil solubility the acceleration and deceleration ramps have to be reduced in order to prevent foaming in oil separator.**

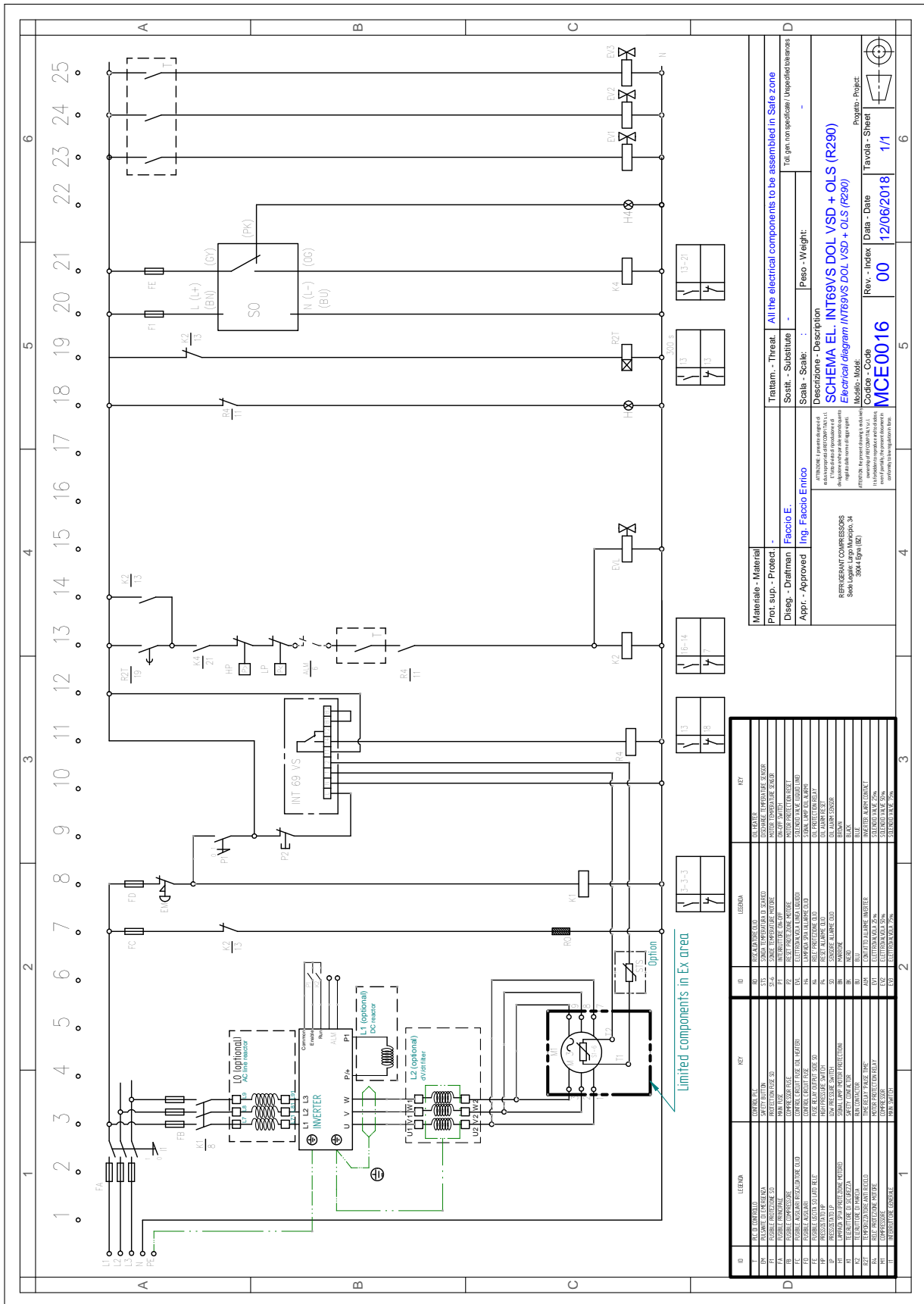

Fig. 24 Electrical connection for Variable frequency drive

The motor speed control has to be regulated between minimum and maximum speed with smooth and reduced variation of load. Refer to the picture below for a reference of time and speed variation.

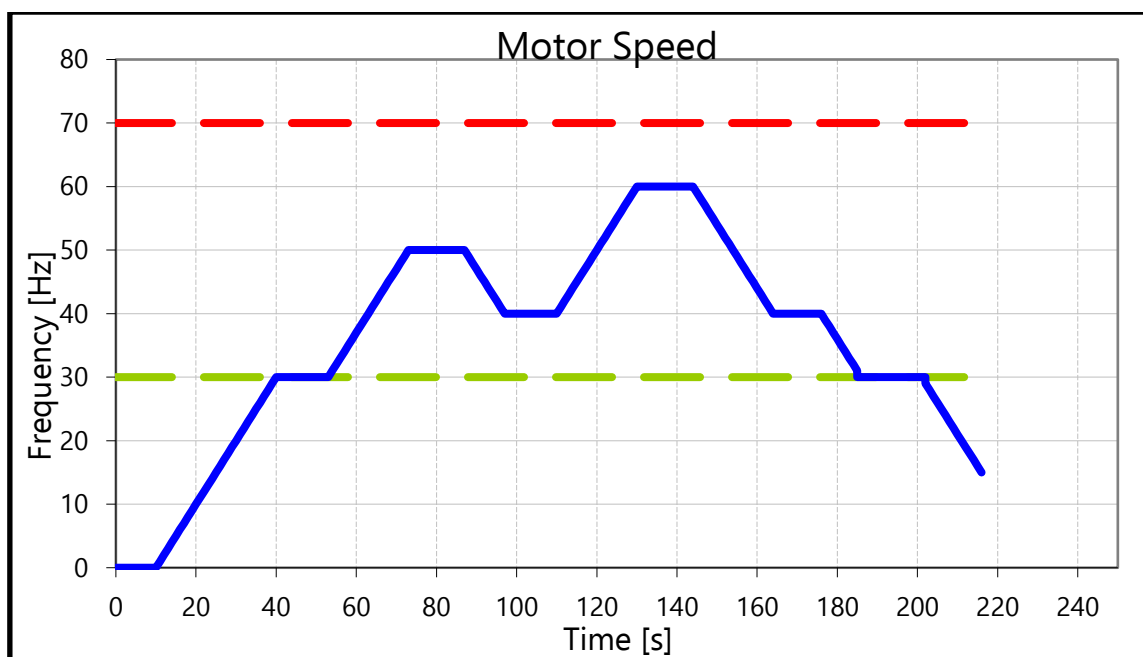

Fig. 25 Speed vs Time variation example

#### 4.5 Procedure for starting and stopping the compressor

To limit the peak current when starting, the electric motors are started in the part-winding configuration, or alternatively with the windings connected in the star configuration (see chapter 6: 'Electrical devices'). This, however, means also a drop in the starting torque, and as a result the resisting torque needs to be reduced in order to start the compressor without excessively overloading the electric motor. For this purpose, SRMTEC recommends to start the compressors at the minimum capacity step, see Fig. 26. Concerning the RS3 series compressors, distinction needs to be made between the step and the stepless configuration.

In the configuration with 4 steps the slide valve automatically returns to the position of minimum capacity after the compressor stops. In fact, due to the pressure difference the oil can flow out of the cylinder to the crankcase through the pipe marked by number 20, see Fig. 17. Therefore the compressor can start again at the minimum capacity.

In the infinite configuration, on the other hand, this pipe is closed by the solenoid valve (19), see Fig. 22, which is normally closed. Consequently, unless the solenoid valve (14) is energized before stopping, the oil cannot flow out of the cylinder and as a result the compressor is not discharged.

For this reason, so as to stop and re-start the compressor at the minimum capacity step the valve (14) must be energized for around 25 seconds before switching off the compressor, see Fig. 26. Moreover the valve (14) should be kept energized during the compressor standstill periods.

The starting and stopping procedure indicated in Fig. 26 has to be followed for all the screw compressors, both in the step and in the stepless version, as this avoids noisy stopping due to the temporary reverse rotation with high mass flow.



#### Attention!

If it is necessary to shutdown for an emergency, the compressor will stop at the current capacity step. In the stepless configuration then, before restarting the unit, make sure that the compressor is at the minimum capacity step.

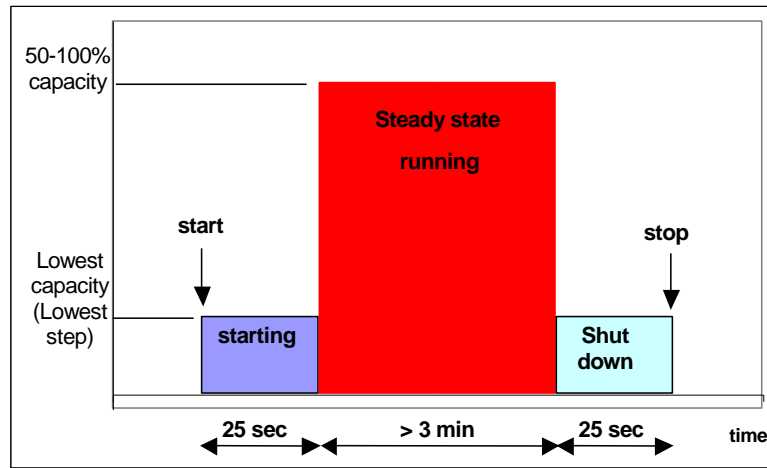

Fig. 26: starting and stopping the compressor;

## 4.6 Operating limits at part load

Operation at part load increases the discharge temperature (it is recommended not to exceed 110° C), and reduces the cooling effect of the electrical motor due to the reduced refrigerant flow. At the same time the partial load operation has a slightly lower efficiency than at full load.

In particular, the discharge temperature increases if:

- The condensing pressure increases;
- The evaporating pressure decreases;
- The temperature of the suction gas (superheat) increases.

To define the operating limits at part load, see chapter 11: "*Application range*".

The pictures below exemplify, through the highlighted area, the limited application envelopes at partial load.

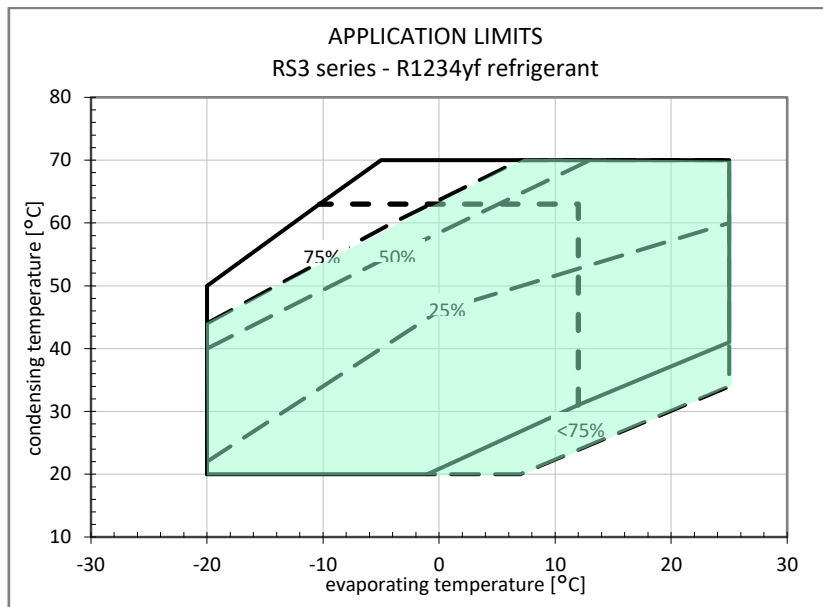

Fig. 27 Example of limited application limit at 75% load

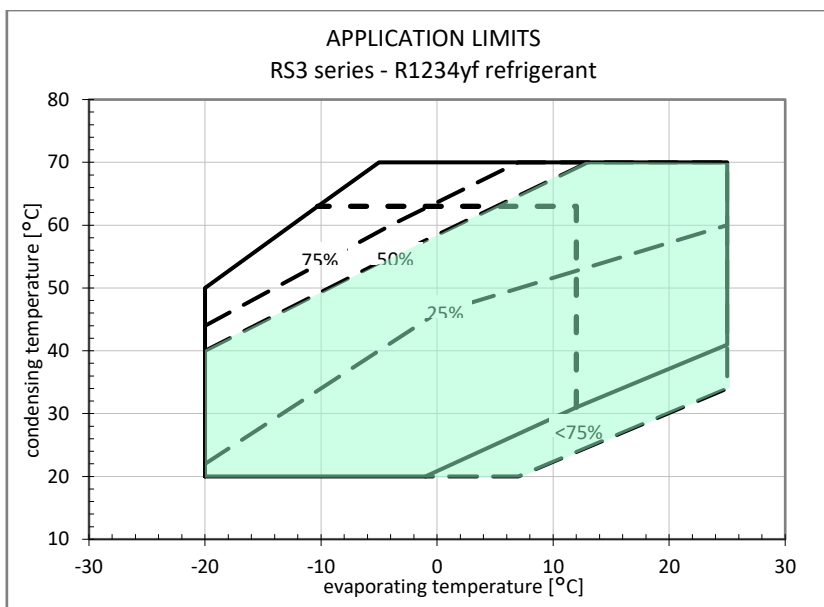

Fig. 28 Example of limited application limit at 50% load

## 5 Components

### 5.1 Suction filter (standard)

The suction filters of the RS3 compressor range could be of different shapes, illustrated below:

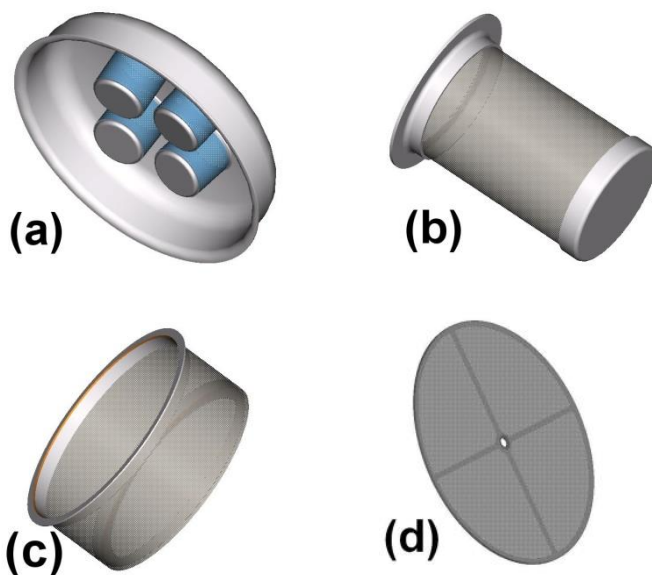

Fig. 29 Suction filters shape

Some models give also the possibility to inspect and clean without disassembling the suction valve.

On the table below the shape and possibility of inspection of the suction filter is indicated according to the compressor model:

RS3	H040	H050	H060	H070	H080	H100	H110	H120	H140	H160	H180	H200	H220	H240	H270	H300	H350	H390
	L030	L040	L050	L060	L070	L080	L090	L100	L120	L140	L150	L160	L180	L200	L220	L240	L270	L300
Filter shape	(a)			(b)			(b)			(b)			(c)			(d)		
Inspectable by	Disassembling suction valve and cover			Disassembling suction valve			Disassembling suction valve			Disassembling suction valve			Disassembling suction valve and cover			Disassembling suction cover		

Table 9: suction filter shape and possibility to inspect

Refrigerant are good solvents for sediments, grease and oil in the pipe work; large quantities of contaminants can end up in the compressor and controls.



**Attention!**

- Apply maximum cleanliness for pipelines and components.
- Braze under a protective gas (use dry nitrogen).
- Follow cleanliness requirements according DIN 8964 or comparable standards
- Apply suction side cleaning filter in case of widely extended systems.

## 5.2 Safety valve (standard)

The compressors are fitted with a safety valve that when necessary opens a passageway between the high and low pressure sections, see Fig. 30. The valve is sized in accordance with the European standard EN 700-24035-2-34. The safety valve opens when the pressure differential, between discharge and suction, exceeds 30 bar, and closes again automatically.

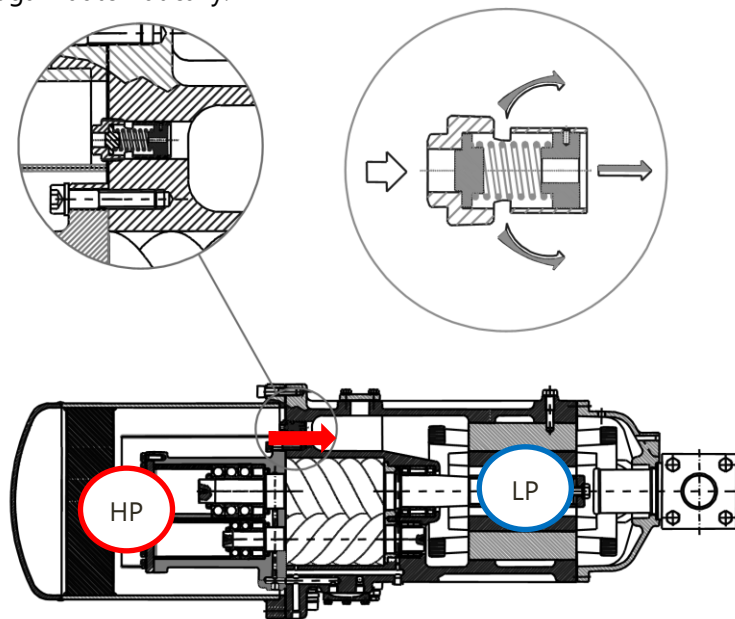

Fig. 30: safety valve shape and position



**Attention!**

- The compressor safety valve is intended exclusively for compressor protection
- The compressor safety valve has, for any reason, not to be considered for the protection of the refrigerating system.

## 5.3 Check valve (standard)

To avoid the backflow of the gas when the compressor stops, due to the pressure difference, the compressor is fitted with a check valve installed immediately upstream of the discharge shut-off valve, see Fig. 31.



**Attention!**

When the compressor stops, following the balancing of the pressure, there is a temporary reverse rotation of the rotors, which produces a typical noise. If this noise lasts more than 3 seconds, check and if necessary replace the check valve.



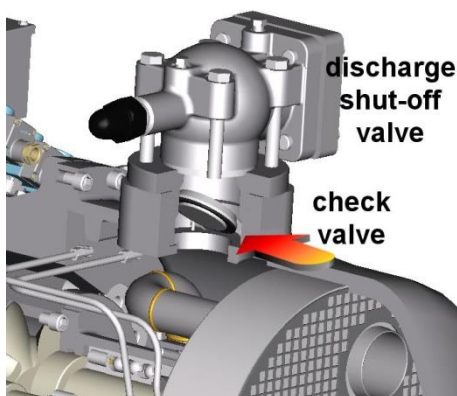

Fig. 31: check valve

### 5.4 Rubber vibration damper (standard)

The compressors are delivered with as standard with a vibration dampers kit, inserted only for shipment in the electrical box.

Fig. 32 below shows the location of the rubber vibration dampers underneath the 4 feet of the RS3 compressor.

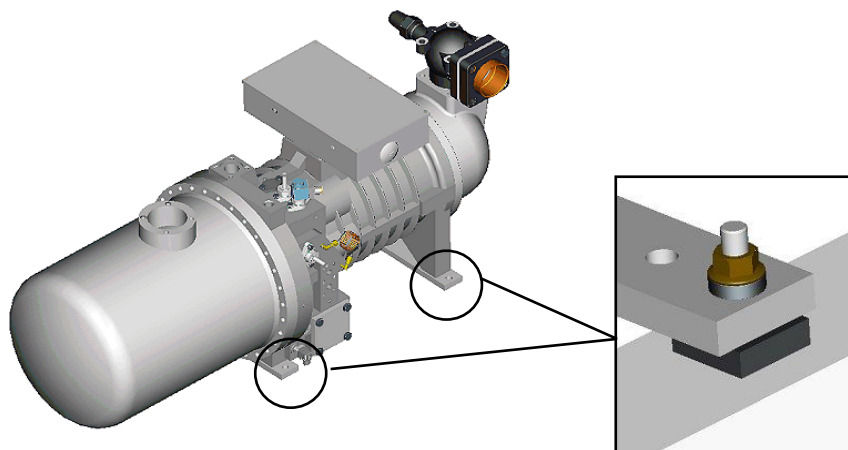

Fig. 32: position of the rubber vibration damper underneath the 4 feet of the compressors;



In order to completely fulfil their purposes, the vibration dampers must be compressed as little as possible and the exact tightness of the self-locking bolt is achieved when the deformation of the vibration damper bushing is around 0.5 mm less than its size when relaxed.

Fig. 33 and Fig. 34 respectively show the correct assembly of the vibration damper, and the assembly diagram for all the components included in the kit.

Below are the codes of the vibration damper kit for all the series models.

RS3	H040	H050	H060	H070	H080	H100	H110	H120	H140	H160	H180	H200	H220	H240	H270	H300	H350	H390
	L030	L040	L050	L060	L070	L080	L090	L100	L120	L140	L150	L160	L180	L200	L220	L240	L270	L300
Vibration damper kit	303243								303321									



Fig. 33: correct assembly of the vibration dampers;

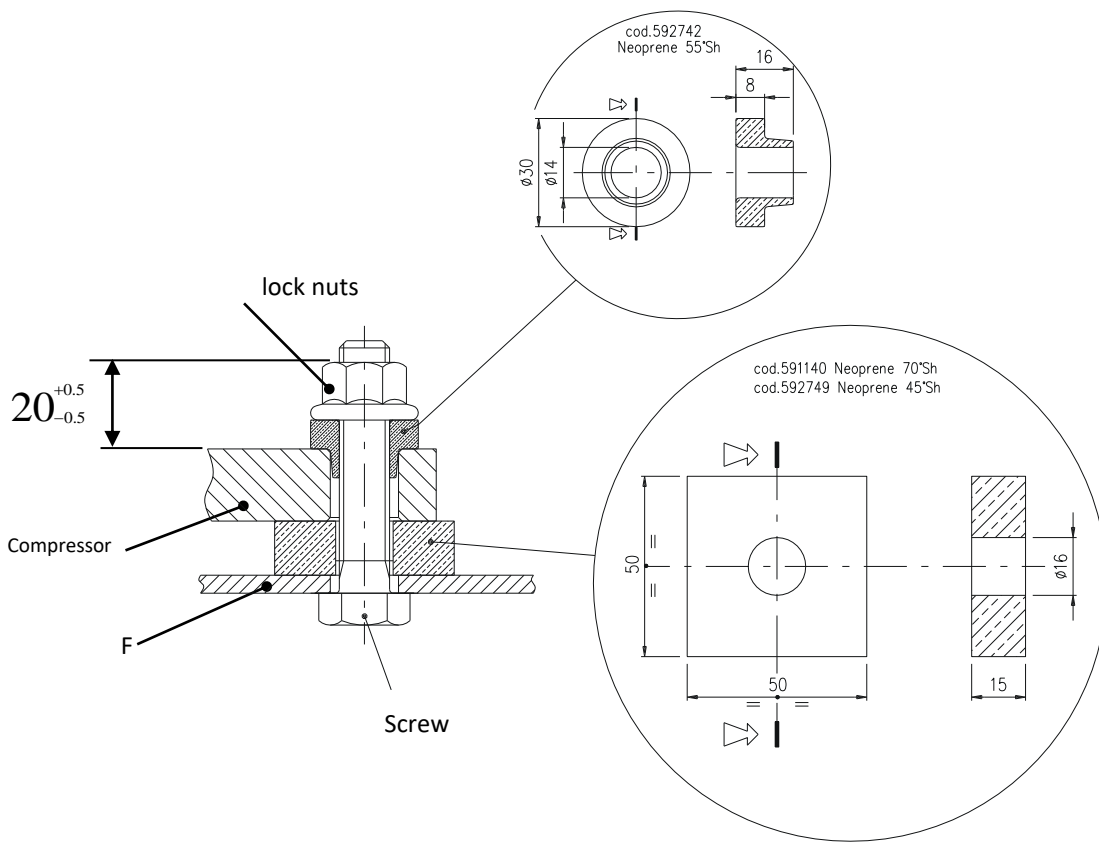

Fig. 34: assembly diagram for the rubber vibration dampers;

## 5.5 Oil flow switch (optional)

The flow switch kit is available upon request to check the correct circulation of the oil in the compressor.  
The following kits are available, depending on the model and the voltage:

RS3 Model	Oil flow switch Kit				Components layout
	Basic	With INT69B2 module			
		24V-50/60Hz	110V-50/60Hz	230V-50/60Hz	
H040 L030	303039	303038	303037	303036	<p>KIT CON protezione motore INT69B2: KIT WITH motor protector INT69B2: 581250 (230V) 581900 (110V) 581910 (24V) solo su kit con protezione motore. only on kit with motor protector.</p> <p>680334 (Condensatore elettrolitico). 680334 (Electrolytic capacitor). solo su kit con protezione motore. only on kit with motor protector.</p> <p>583473 optional</p> <p>1 c.s./Torque 80Nm 2 c.s./Torque 40Nm 3 c.s./Torque 50Nm 4 c.s./Torque 15Nm 5 c.s./Torque 80Nm 6 c.s./Torque 15Nm 7 c.s./Torque 15Nm 8 c.s./Torque 15Nm 9 c.s./Torque 15Nm 10 c.s./Torque 15Nm 11 c.s./Torque 15Nm</p> <p>Usare Loctite 577 (gialla). Use Loctite 577 (yellow).</p> <p>Tubo Ø16 Pipe Ø16</p>
H050 L040					
H060 L050					
H070 L060					
H080 L070					
H100 L080	303047	303046	303045	303044	<p>680334 (Condensatore elettrolitico). 680334 (Electrolytic capacitor). solo su kit con protezione motore. only on kit with motor protector.</p> <p>581250 (230V) 581900 (110V) 581910 (24V) solo su kit con protezione motore. only on kit with motor protector.</p> <p>Direzione del flusso. Flow direction.</p> <p>1 c.s./Torque 120Nm</p> <p>2 c.s./Torque 120Nm</p> <p>3 c.s./Torque 120Nm</p> <p>4 c.s./Torque 120Nm</p> <p>5 c.s./Torque 120Nm</p>
H110 L090					
H120 L100					
H140 L120	303043	303042	303041	303040	<p>581250 (230V) 581900 (110V) 581910 (24V) solo su kit con protezione motore. only on kit with motor protector.</p> <p>680334 (Condensatore elettrolitico). 680334 (Electrolytic capacitor). solo su kit con protezione motore. only on kit with motor protector.</p> <p>Usare Loctite 577 (gialla). Use Loctite 577 (yellow).</p> <p>583473 optional</p> <p>1 c.s./Torque 80Nm 2 c.s./Torque 15Nm 3 c.s./Torque 80Nm 4 c.s./Torque 15Nm 5 c.s./Torque 15Nm 6 c.s./Torque 70Nm 7 c.s./Torque 50Nm 8 c.s./Torque 50Nm 9 c.s./Torque 50Nm 10 c.s./Torque 50Nm 11 c.s./Torque 50Nm</p>
H160 L140					
H180 L150					
H200 L160					
H220 L180					
H240 L200					

H270 L220	303119	303118	303117	303116	
H300 L240					
H350 L270					
H390 L300					

Table 10 Oil flow switch kits

Please contact SRM Italy Srl for more details on the components of the oil flow switch kit and technical details.

	<p><b>Warning!</b>  <b>THE PROTECTION MODULE MUST NOT BE INSTALLED FOR ANY REASON INSIDE THE ELECTRICAL BOX when used with A2L refrigerants!</b></p>
	<p><b>The sparks produced by the internal relay could provoke and ignition.</b>  <b>Is mandatory to install the protection module in an Electrical box installed in a Safe Zone.</b></p>

Technical specifications of the flow switch:

- Switch value: 6 l/min H<sub>2</sub>O (N. 680015) and 10 l/min H<sub>2</sub>O (N. 680016)
- Voltage supply: 250V AC – 1A – 60VA
- Max temperature: 85°C

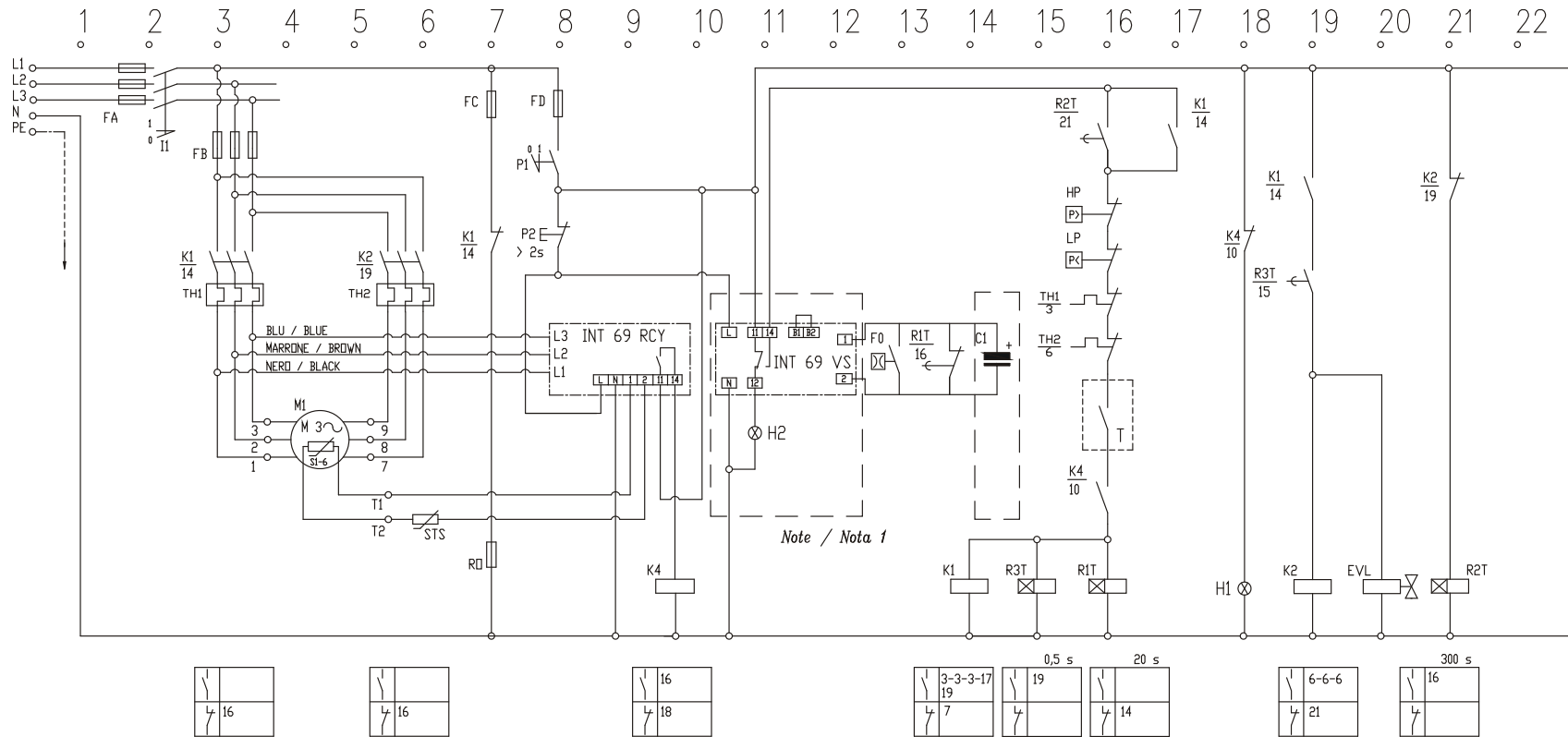

## KEY:

T	CONTROL THERMOSTAT	M	COMPRESSOR
FA	MAIN FUSE	H	MAIN SWITCH
FB	COMPRESSOR FUSE	RO	OIL HEATER
FC	CONTROL CIRCUIT FUSE (OIL HEATER)	STS	DISCHARGE TEMPERATURE SENSOR
FD	CONTROL CIRCUIT FUSE	SI-6	MOTOR TEMPERATURE SENSOR
HP	HIGH PRESSURE SWITCH	P1	ON-OFF SWITCH
LP	LOW PRESSURE SWITCH	P2	MOTOR PROTECTION RESET
H1	SIGNAL LAMP (MOTOR PROTECTION)	EVL	SOLENOID VALVE (LIQUID LINE)
K1	START CONTACTOR	H2	SIGNAL LAMP (OIL FLOW FAULT)
K2	RUN CONTACTOR	R1T	TIME RELAY (OIL FLOW CONTROL)
R2T	TIME RELAY "PAUSE TIME"	C1	ELECTROLYTIC CAPACITOR
R3T	TIME RELAY START - RUN	FO	OIL FLOW SWITCH
K4	MOTOR PROTECTION RELAY	TH1	RELAY OVERCHARGE FIRST WINDING
		TH2	RELAY OVERCHARGE SECOND WINDING

Fig. 35: wiring diagram for the connection of the flow switch; electric motor with part-winding configuration PW (MCE007\$2);  
 Note 1: INT 69 B2 and electrolytic capacitor included only in appropriate kits.

Pag. 46 di 100

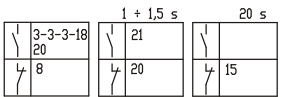
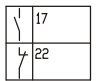
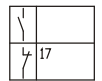
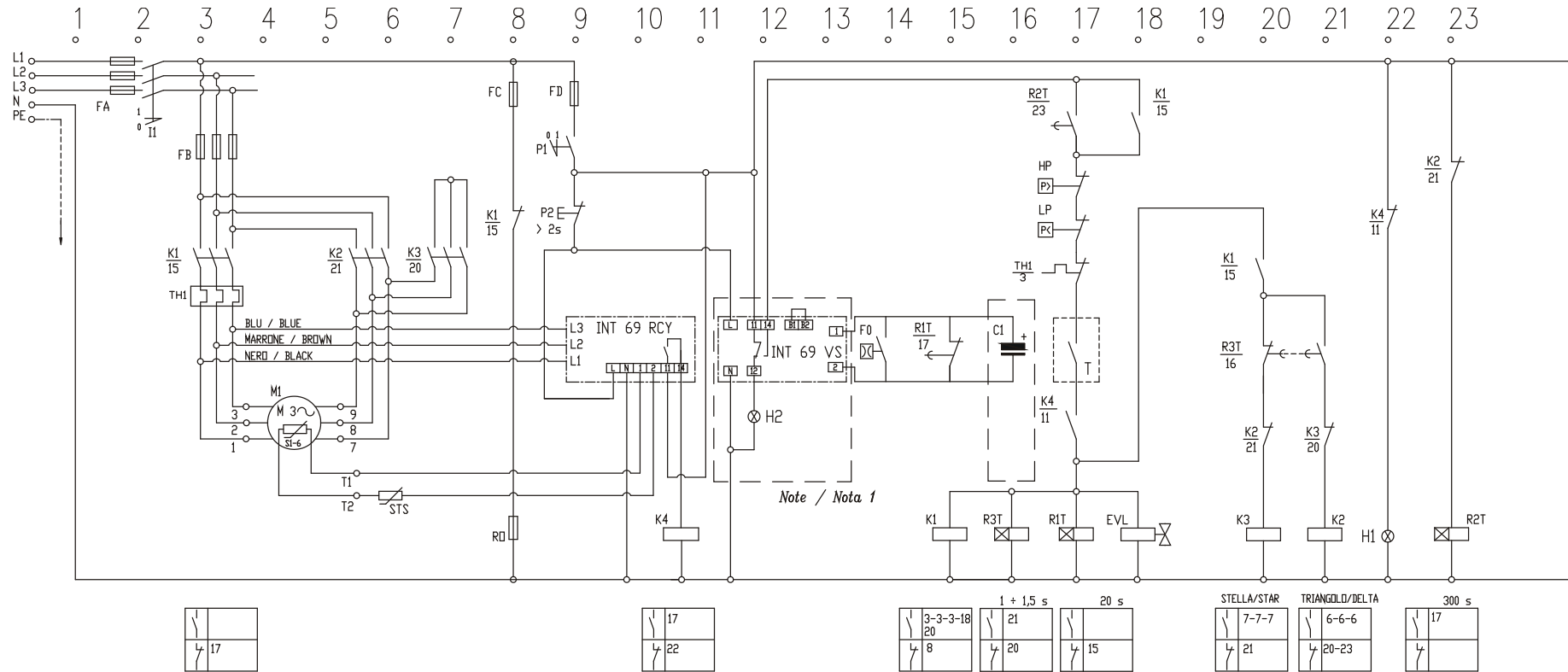

- KEY:**
- |     |                                   |      |                               |
|-----|-----------------------------------|------|-------------------------------|
| T   | CONTROL THERMOSTAT                | M    | COMPRESSOR                    |
| FA  | MAIN FUSE                         | H    | MAIN SWITCH                   |
| FB  | COMPRESSOR FUSE                   | RO   | OIL HEATER                    |
| FC  | CONTROL CIRCUIT FUSE (OIL HEATER) | STS  | DISCHARGE TEMPERATURE SENSOR  |
| FD  | CONTROL CIRCUIT FUSE              | SI-6 | MOTOR TEMPERATURE SENSOR      |
| HP  | HIGH PRESSURE SWITCH              | P1   | ON-OFF SWITCH                 |
| LP  | LOW PRESSURE SWITCH               | P2   | MOTOR PROTECTION RESET        |
| H1  | SIGNAL LAMP (MOTOR PROTECTION)    | EVL  | SOLENOID VALVE (LIQUID LINE)  |
| K1  | START CONTACTOR                   | H2   | SIGNAL LAMP (OIL FLOW FAULT)  |
| K2  | RUN CONTACTOR                     | RIT  | TIME RELAY (OIL FLOW CONTROL) |
| K3  | WYE CONTACTOR                     | C1   | ELECTROLYTIC CAPACITOR        |
| R2T | TIME RELAY "PAUSE TIME"           | FO   | OIL FLOW SWITCH               |
| R3T | TIME RELAY START - RUN            | TH1  | RELAY OVERCHARGE MOTOR        |
| K4  | MOTOR PROTECTION RELAY            |      |                               |

Fig. 36: wiring diagram for the connection of the flow switch; electric motor with star-delta configuration YΔ (MCE008\$2);  
 Note 1: INT 69 B2 and electrolytic capacitor included only in kit appropriate.

## 6 Electrical motor



The electrical connection of the machine to the network line must be carried out by the customer at its own expense and responsibility, by use of specialized personnel and in accordance with safety standard EN 60204.



It is mandatory to install upstream of the power supply line a suitable isolating device with residual current protection coordinated with the earth system.



Each connection must be performed under the conditions described in par. 1.5

### 6.1 General

The motor stator is secured to the compressor casing by using a screw and a key. Hence no special tools are required to replace the motor.

The electrical motors are designed and tested in compliance with the European standard EN 700-24035-2-34.

The electric motors are three-phase asynchronous two-pole motors (2900 rpm at 50 Hz). To reduce the peak current, they are available in the part-winding (PW) or star/delta (Y/ $\Delta$ ) version; for the standard supply see Table 15 in paragraph 7.1 Electrical data.

Depending on the compressor model there are two different types of PW motors which differ from each other for the connection of the three phases: star or delta type. In any case at the compressor starting only a part of the windings is powered, while in normal operation all are powered. The PW versions can be:

- ✓ Double star (Y-YY);
- ✓ Double delta ( $\Delta$ - $\Delta\Delta$ ).

As regards the mains connections, there is no difference between the two PW motor configurations. Fig. 37 and Fig. 38 below show the internal connections of the phases, depending on the configuration of the electrical motor.

- **PART-WINDING CONFIGURATION**

**Important note:**

The two above-mentioned part-winding types of motors can be distinguished by measuring the electrical resistance between terminals 1-2-3 and 7-8-9.

With reference to Fig. 37:

- ✓ in the Y-YY configuration there is continuity between terminals 1 and 2, 1 and 3, 2 and 3, 7 and 8, 7 and 9, 8 and 9; while there is insulation between terminals 1 and 7/8/9, 2 and 7/8/9, 3 and 7/8/9.
- ✓ in the  $\Delta$ - $\Delta\Delta$  configuration there is continuity between each pair of terminals and there is not reciprocal insulation between any of them.



PART-WINDING CONFIGURATION

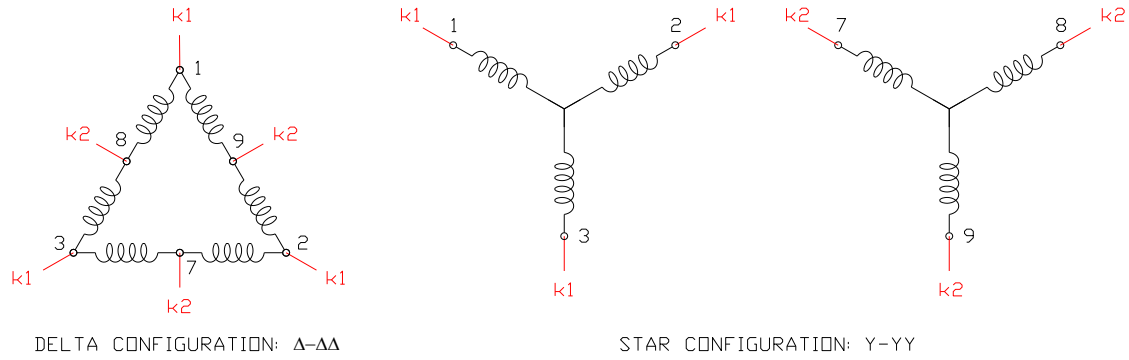

Fig. 37: internal winding connections for the motors with part-winding configuration

• STAR-DELTA CONFIGURATION



**Important note:**

With reference to Fig. 38, measuring the electrical resistance between terminals 1-2-3 and 7-8-9, the star-delta version has the following values: continuity between terminals 1 and 8, 3 and 7, 2 and 9, and insulation between terminals 1 and 2/3/7/9, 2 and 1/3/7/8, 3 and 1/2/8/9, 7 and 1/2/8/9, 8 and 2/3/7/9, 9 and 1/3/7/8.

STAR-DELTA CONFIGURATION

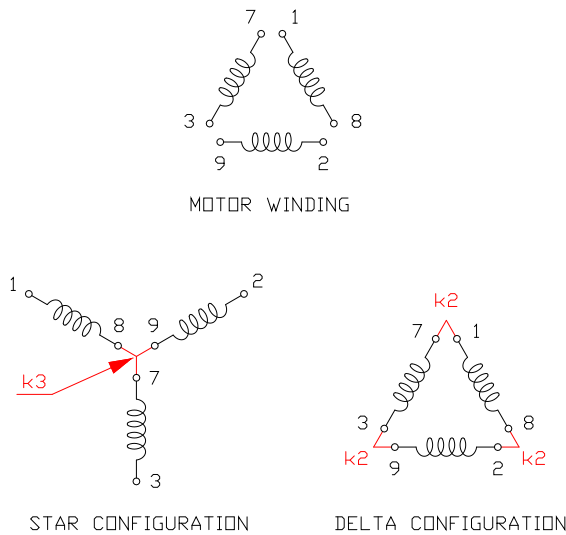

Fig. 38: internal winding connections for the motors with star-delta configuration

By starting the electrical motor either in part-winding configuration or with the windings in star connection for the electrical motor in star-delta configuration there is a reduction in the starting current LRA and starting torque. To achieve a reduction in the resisting torque and consequently start the motor without overloading it, the compressor needs to be started at the minimum capacity step, see chapters 4: "Capacity control" and 0: "Operating instructions".



**Note:**

Then with the screw compressors no by-pass system between the high and low pressure is required for reducing the resisting torque on starting.



Fig. 39 shows how to connect the electrical motor to the three-phase line, both for the star-delta configuration and the part-winding one. It also gives the time sequence for the contactors. The compressor therefore starts as follows:

- ✓ In the PW motors, the delay in closing the run contactor K2 from when the starting contactor K1 closes must be 1 second maximum (recommended value 0.6 sec), see Fig. 39.
- ✓ In the star-delta configuration, on the other hand, the starting duration in star configuration (closing of contactors K1-K3) must not exceed 1.5 sec (recommended value 0.8/1 sec); while when switching to delta configuration (closing of contactors K1-K2), contactor K2 must be closed with a delay of 35-50 msec from the instant when contactor K3 is opened, see Fig. 39 again.

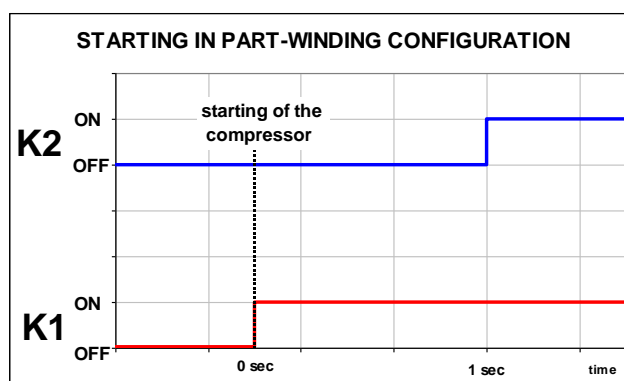
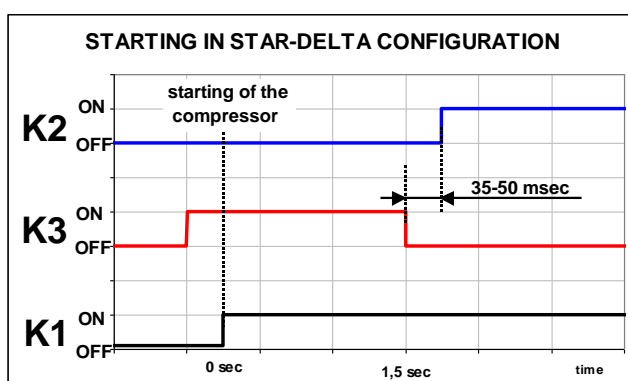
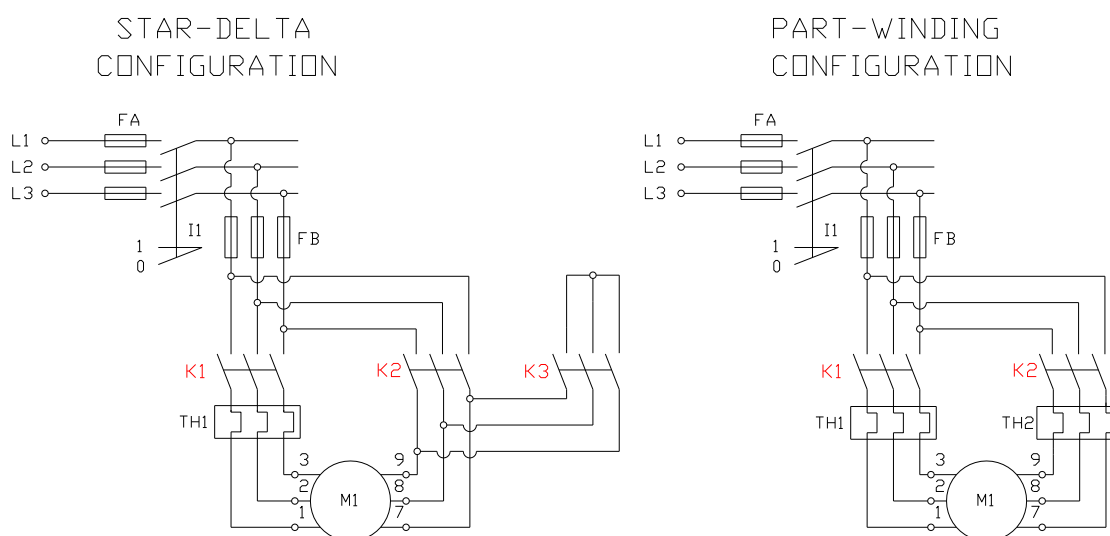

Fig. 39: connection diagrams to the three-phase network and time charts for the activation of contactors K1, K2 and K3 in the two compressor starting modes: star-delta and part-winding;

FA, FB: main fuses and compressor's fuses

I1: main switch; M1: electrical motor; TH1, TH2: overload relay;

## 6.2 Protection devices

### 6.2.1 Motor thermistors (standard)

To protect the motor against high temperatures six PTC thermistors connected in series are inserted in the motor windings. Three thermistors are positioned on the intake side of the motor (suction side) and have

an activation temperature of 100°C, while the other three are positioned on the opposite side of the motor (discharge side) and have an activation temperature of 120°C.

The resistance of the chain of thermistors when cold (temperature less than 40°C) must be less than 1800 Ohm; but even if just one of the thermistors reaches the critical temperature, the resistance of the chain will increase exponentially, with the consequent activation of the INT 69 B2 electronic module (INT 69 SNY as an option), which cut off the power supply to the motor. The resistance can be measured between terminals T1 and T2 on the terminal block.



### Attention !

When measuring the resistance of the thermistors' chain, never apply a voltage higher than 3V.

#### 6.2.2 INT 69 B2



#### Warning!

**THE PROTECTION MODULE MUST NOT BE INSTALLED FOR ANY REASON INSIDE THE ELECTRICAL BOX with A2L refrigerants!**



**The sparks produced by the internal relay could provoke and ignition.**

**Is mandatory to install the protection module in an Electrical box installed in a Safe Zone.**

This electronic protection module is supplied as standard with the compressor and in combination with the thermistors it carries out the function of monitoring the temperature of the electrical motor windings. The thermistors in the motor can be connected in series to a further PTC probe for monitoring the temperature of the oil (set point 120°C; Fig. 42 shows the position of the temperature sensor in the compressor; see also chapter 12: "*Additional cooling*").

The protection device is electrically connected by the manufacturer as shown in Fig. 40. For the technical specifications of the module, see Table 11.

Activation threshold	4500 Ohm;
Reset threshold	2750 Ohm;
Power supply	115-230 V $\pm$ 10%, 50/60 Hz, 3VA;
Switching relay	250 V AC, max 2.5 A, switch capacity 300 VA At least AC/DC 20mA
Ambient temperature	-30° C...+70° C
Fuse required	4 A quick blow

Table 11: INT 69 B2 technical specifications

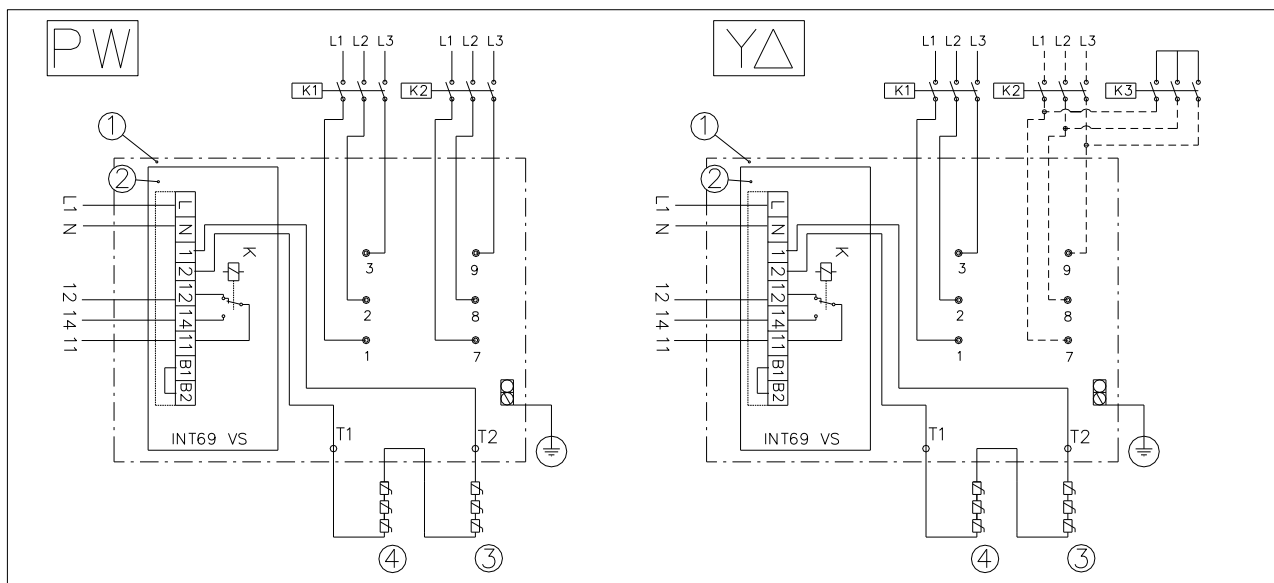

Fig. 40: electrical connections to the INT 69 B2 module (part-winding and star delta);

1	Terminal plate	L1/N	Phase + neutral
2	Motor protection device INT 69 B2	11/14	Control circuit
3, 4	Motor thermistors PTC	1/2	Connection cables to thermistor (orange)
L1, L2, L3	Supply voltage	12	alarm
PW	K1 Contactor 1st PW (PW 50%) K2 Cont. 2nd PW (PW 50%)	B1, B2	Link for automatic reset
Y/ ·	K1 and K3 Start contactors (Y) K1 and K2 Run contactors ( · )	K	Relay (supplied fitted)



To protect the electronic module, it is recommended to install a 4A fast-blow fuse to prevent the contacts from melting in the event of short-circuits.

The correct operation of the module must be checked when testing the installation and after any fault occurred in the auxiliary circuit. For this purpose, remove one of the connection wires from terminals T1 and T2 on the terminal block (not powered). When supplying power to the auxiliary control circuit, the power runs between terminals 12 and N, signaling an alarm.

In the event where the thermal protector on the electric motor is activated, this must be reset by specialist personnel. The device can only be reset after the causes of activation have been identified and removed.

### Attention!



Following an alarm and after the motor has cooled down, an internal lockout prevents the compressor from starting again.

1. Reset the INT 69 B2 module by briefly disconnecting the power supply through the main switch or by pressing a specific button that can be installed for this purpose in the power supply line.
2. Never apply power to the module terminals 1-2, B1-B2, nor to terminals T1 and T2 of the terminal plate.

A phase monitor must be installed to check the correct direction of the electrical motor rotation.



### 6.2.3 INT 69 SNY (optional)

 	<p><b>Warning!</b>  <b>THE PROTECTION MODULE MUST NOT BE INSTALLED FOR ANY REASON INSIDE THE ELECTRICAL BOX!</b>  <b>The sparks produced by the internal relay could provoke and ignition.</b>  <b>Is mandatory to install the protection module in an Electrical box installed in a Safe Zone.</b></p>
--	---

The INT 69 SNY module is available as an optional. This module carries out the following functions:

- ✓ monitors the temperature of the electrical motor and the oil;
- ✓ monitors the direction of rotation of the motor;
- ✓ monitors for a missing phase.

The electrical connections on the INT 69 SNY protection module are shown in Fig. 40 (PW and Star/Delta). For the technical specifications of the module see Table 13 in the following pages.

#### Monitoring the temperature

The temperature of the motor and the oil are monitored by the PTC sensors. The oil temperature sensor is connected in series to the chain of thermistors in the electrical motor (for its position of the sensor on the compressor see Fig. 42).

Manual reset of alarm through disconnection of power supply for at least 5 seconds .

The temperature is monitored through its value (static control) and through the swiftness of its increase (dynamic control).

Only when the alarm is given by the temperature static control, and only if the reset level has been reached, the motor protector will perform an automatic reset after 5 minutes from the alarm detection.

#### Attention!

Following an alarm and after the motor has cooled down, an internal lockout prevents the compressor from starting again.



1. Reset the INT 69 SNY module by briefly disconnecting the power supply through the main switch or by pressing a specific button that can be installed for this purpose in the power supply line.
2. Never apply power to the module terminals 1-2, B1-B2, nor to terminals T1 and T2 of the terminal plate.



TAKE NOTE: Before re-starting the compressor following an alarm, the operator must check the temperature of the motor and the oil temperature, making sure that the resistance of the PTC chain is less than 2,9 kΩ.

#### Monitoring the direction of rotation of the motor

The correct direction of rotation of the motor is monitored by measuring the sequence of the phases at the compressor terminals.

The function has a manual reset and requires the power supply to be disconnected for at least 5s . The check is performed in the first 5 seconds at each starting.



#### Attention!

Following an alarm for wrong rotation, an internal lockout prevents the compressor from starting again.



1. Put the system in the Machine switched-off status
2. Reset the INT 69 SNY module by briefly disconnecting the power supply through the main switch or by pressing a specific button that can be installed for this purpose in the power supply line.



3. Before re-starting the compressor check the correct sequence of the phases

## Monitoring for a missing phase

The phases are monitored during the start-up and. The alarm causes the stop of compressor and it could not start before 5 minutes.

So the reset is automatic till maximum 10 consecutive restarts (in the first 24 hours of working) with a missing phase the compressor is stopped definitively. After this, it must be reset manually by disconnecting the power supply for at least 2 seconds.



### Attention!

Following a repeated alarm for missing, an internal lockout prevents the compressor from starting again.



4. Put the system in the Machine switched-off status
5. Reset the INT 69 SNY module by briefly disconnecting the power supply through the main switch or by pressing a specific button that can be installed for this purpose in the power supply line.
6. Before re-starting the compressor check the power supply of the compressor.

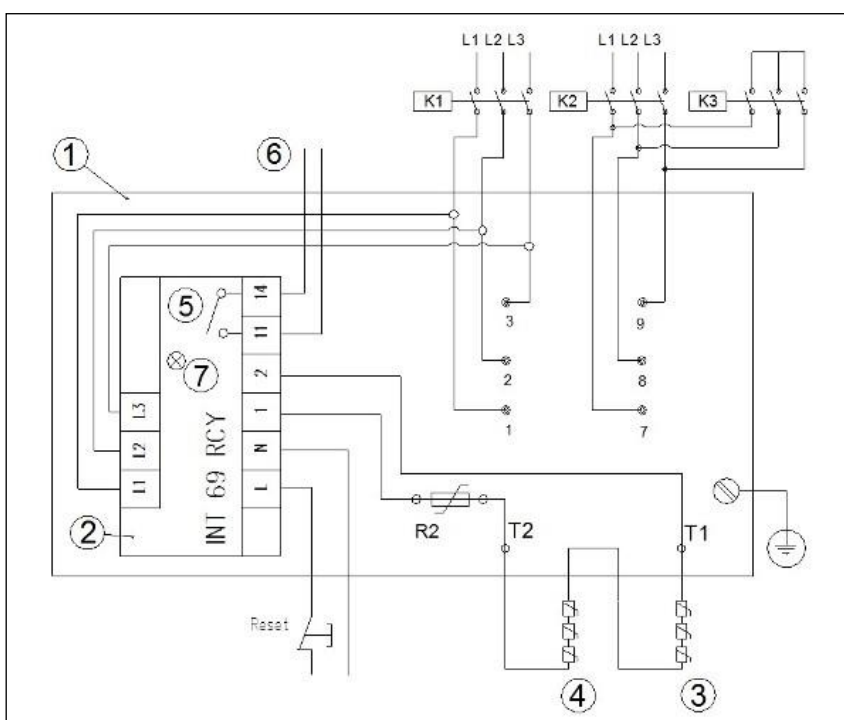

- |                                       |                                       |
|---------------------------------------|---------------------------------------|
| 1) Terminal box                       | L/N) Phase + neutral 230V-50/60Hz     |
| 2) Motor protection device INT 69 SNY | 6) Control circuit                    |
| 3-4) Motor thermistors PTC            | 1/2) Connection cables to thermistors |
| R2) Discharge gas temperature sensor  | 5) Relay                              |
| L1-L2-L3) Power supply                | 7) Led                                |
| PW motor: K1 PW contactor 50%         |                                       |
| K2 PW contactor 50%,                  |                                       |
| Y/D motor: K1-K3 start contactors (Y) |                                       |
| K1-K2 run contactors (D)              |                                       |

Fig. 41: electrical connections to the INT 69 SNY module (part-winding and star delta)

Trip value	4500±20% Ohm
Reset value	2750±20% Ohm
Power supply	115/120 V or 230/240 V -15/+10%, 50/60 Hz, Absorbed power : 3VA
Output relay	AC, 240 V, 2,5A max continuous current, C300 Potential-free normally open contact (NOC)
Ambient working conditions (temp.)	-30°C...+70°C
Required fuse	4 A, fast type
Motor supply	200...690V AC ±10%, 3 AC, 50/60 Hz

Table 12: INT 69 SNY technical specifications;

The INT 69 SNY has to be fitted in a main control box far away from the compressor according to the following indications:

- ✓ The connection cables to the motor terminals must be connected following the specified sequence: L1 to terminal 1, L2 to terminal 2 and L3 to terminal 3; check the direction of rotation with an indicator;
- ✓ To connect the module to the PTC sensors, only use shielded cables or a twisted pair (danger of induction);

### Alarm signals

The motoprotector INT 69 SNY is equipped on its box with a led for displaying the kind of the alarm occurred. The kind of optic signalling identifies the motoprotector status and in case of alarm also its cause.

- ✓ Solid GREEN Led: fault-free status
- ✓ Blinking RED Led: alarm status

Through the cyclical sequence of the red blinks it is possible to identify both the category and the type of the detected alarm.

Specifically, with reference to the table and examples reported below, the blinking cycle can be divided onto two subsequent sequences: at first that of the alarm category and afterwards that of the alarm type.

#### - 1^ cycle sequence (alarm category):

- ✓ 1 blink followed by a pause of 1 second identifies alarms caused by the electric motor temperature (PTC) or by the discharge temperature;
- ✓ 2 blinks followed by a pause of 1 second identify alarms caused by the electrical phases (Phase Monitoring).

#### - 2^ cycle sequence (alarm type, in succession to the first sequence):

A certain number of blinks according to the alarm type (look at the following table), followed by a pause of 2,5 seconds.

Error Category		Fault Type	
Number of Flash	Error Category	Number of Flash	Fault Type
1	PTC	1	Static
		2	Dynamic
		3	Time delay active (PTC < Restart Limit)
2	Phase Monitoring	1	False phase sequence
		2	Phase failure

Table 13 INT69SNY Alarm Signal

For your convenience hereby we report a couple of examples:

1. "PTC" alarm caused by a too fast increase of the motor temperature.

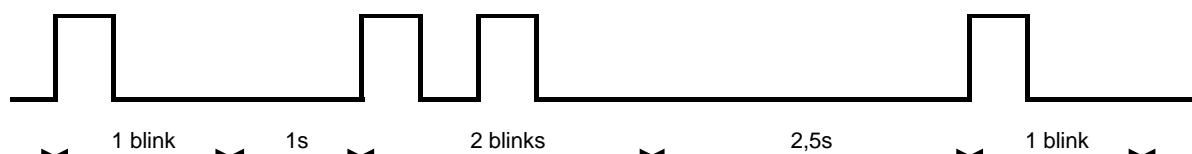

2. "Monitoring Phase" alarm caused by wrong phase sequence.



## 6.2.4 Lubricant/Discharge temperature probe (optional)

The lubricant and discharge temperature could be protected from excessive values with the installation of a temperature probe.

The Fig. 42 illustrate the position of installation of the temperature probe on the compressors.

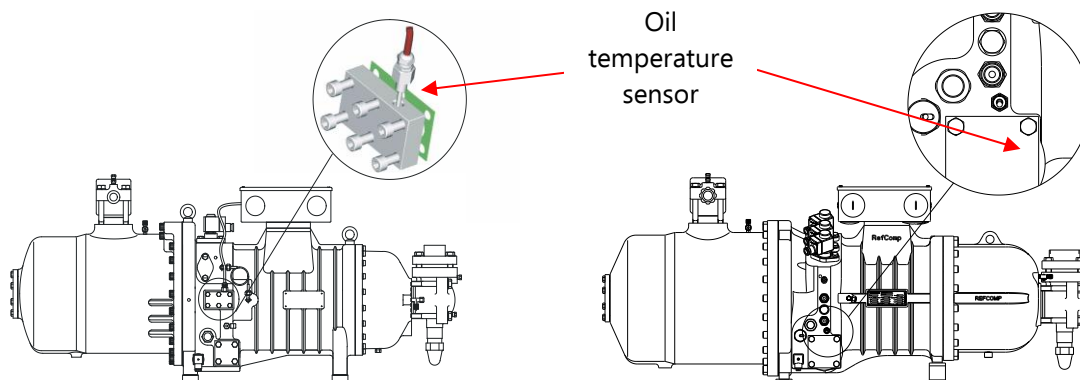

Fig. 42: position on compressor for oil temperature monitoring sensor

The temperature sensor is of PTC type with the following parameters, according to DIN 44081:

Max. operation voltage	30V
Reset value	2750±20% Ohm
Nominal tripping value	120°C
Ambient working conditions (temp.)	-25°C...+60°C
Max. operating temperature	+180°C
Max. operating pressure	46bar

Table 14: Temperature probe technical specifications

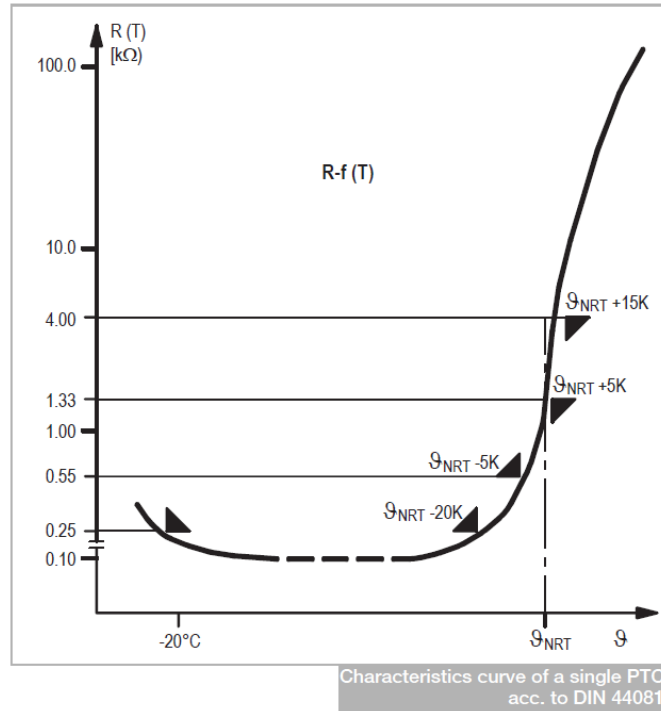

Fig. 43 Characteristics response curve of a single PTC

### 6.3 Power supply



#### Warning!



**For the direction of rotation of the rotors see chapter 2 General. If the motor turns in the opposite direction the compressor can be seriously damaged.**

- Motor power supply for standard version (part-winding and star-delta):  
400 V - 3 phases - 50 Hz / 460 V - 3 phases - 60 Hz (other power supply on request);
- Permissible voltage range: ± 10 % of rated voltage;
- Permissible voltage unbalance between L1 - L2 - L3: ± 2 %;
- Maximum voltage drop during the starting phase: 10 % of rated voltage;
- Permissible frequency range: ± 2 % of rated frequency;
- Permissible current unbalance: 5 /12 % calculated as follows:

Currents on the first contactor:  $I_1 - I_2 - I_3$

Currents on the second contactor:  $I_7 - I_8 - I_9$

Currents of each supply phase

$$I_R = I_1 + I_7$$



$$I_S = I_2 + I_8$$

$$I_T = I_3 + I_9$$

Unbalance of the three R - S - T currents:

$$I_M = \frac{I_R + I_S + I_T}{3}$$

$$SB_3^{\%} = \frac{\text{MAX}(I_R, I_S, I_T) - I_M}{I_M} \cdot 100$$

$$SB_3^{\%} < 5\%$$

Unbalance of the six 1 - 2 - 3 - 7 - 8 - 9 currents:

$$I_M = \frac{I_1 + I_2 + I_3 + I_7 + I_8 + I_9}{6}$$

$$SB_6^{\%} = \frac{\text{MAX}(I_1, I_2, I_3, I_7, I_8, I_9) - I_M}{I_M} \cdot 100$$

$$SB_6^{\%} < 12\%$$

## 6.4 Selection of electrical components

The various electrical components: cables, fuses etc. must be sized considering the maximum current that can be absorbed by the electrical motor during normal operation, i.e. the FLA.

Specifically, erring on the side of safety, in Part-Winding configuration the contacts on the motor contactors must be sized for a current equal to at least 65% of the maximum operating current (FLA). On the other hand, for the star-delta configuration the contacts must be sized for a current equal to at least 75% of the FLA.

## 7 Data

### 7.1 Electrical data

Mod. RS3		H040	H050	H060	H070	H080	H100	H110	H120	H140	H160	H180	H200	H220	H240	H270	H300	H350	H390	
Nominal motor power	HP (kW)*	40 (30)	50 (37)	60 (45)	70 (52)	80 (60)	100 (75)	110 (82)	120 (90)	140 (105)	160 (120)	180 (135)	200 (150)	220 (164)	240 (179)	270 (200)	300 (224)	350 (261)	390 (291)	
<b>Motor - Motore 1 (full size)</b>																				
Nominal Voltage (V)	V	400/3/50Hz - 460/3/60Hz																		
PW	Starting current (A)	LRA Y	277	303	373	280	351	495	586	646	-	-	-	-	-	-	-	-	-	-
		LRA YY	398	406	547	459	580	770	965	770	-	-	-	-	-	-	-	-	-	-
	Max running current (A)	FLA	80	90	96	124	140	168	192	196	-	-	-	-	-	-	-	-	-	-
Y/Δ	Starting current (A)	LRA Y	131	134	182	159	193	254	322	318	354	374	453	543	595	595	595	876	1062	1062
		LRA Δ	398	406	547	459	580	770	965	953	1155	1155	1333	1645	1802	1802	1802	2627	3186	3186
	Max running current (A)	FLA	80	90	96	124	140	168	192	196	225	245	270	300	334	400	400	545	600	650
Standard Delivery - Fornitura standard																				

Table 15: electrical data of the compressors (full size motor)

Mod. RS3		L030	L040	L050	L060	L070	L080	L090	L100	L120	L140	L150	L160	L180	L200	L220	L240	L270	L300	
Nominal motor power	HP/kW*	30 (22)	40 (30)	50 (37)	60 (45)	70 (52)	80 (60)	90 (67)	100 (75)	120 (90)	140 (105)	150 (110)	160 (120)	180 (135)	200 (150)	220 (164)	240 (179)	270 (201)	300 (224)	
<b>Motor - Motore 2 (small size)</b>																				
Nominal Voltage (V)	V	400/3/50Hz - 460/3/60Hz																		
PW	Starting current (A)	LRA Y	277	277	303	262	280	351	351	495	-	-	-	-	-	-	-	-	-	-
		LRA YY	331	398	406	422	459	580	580	770	-	-	-	-	-	-	-	-	-	-
	Max running current (A)	FLA	50	62	68	79	96	105	117	130	-	-	-	-	-	-	-	-	-	-
Y/Δ	Starting current (A)	LRA Y	109	131	134	139	159	193	193	254	276	354	374	453	543	543	543	783	876	1062
		LRA Δ	331	398	406	422	459	580	580	770	876	1155	1155	1333	1645	1645	1645	2348	2627	3186
	Max running current (A)	FLA	50	62	68	79	96	105	117	130	156	168	185	205	229	267	267	400	435	490
Standard Delivery - Fornitura standard																				

Table 16: electrical data of the compressors (small size motor);

## 7.2 Technical data

Mod. RS3		H040 L030	H050 L040	H060 L050	H070 L060	H080 L070	H100 L080	H110 L090	H120 L100	H140 L120	H160 L140	H180 L150	H200 L160	H220 L180	H240 L200	H270 L220	H300 L240	H350 L270	H390 L300	
Nominal motor power	HP/ kW*	40/30	50/37	60/45	70/52	80/60	100/75	110/82	120/90	140/ 105	160/ 120	180/ 135	200/ 150	220/ 164	240/ 179	270/ 200	300 / 224	350 / 261	390 / 291	
Displacement at 50/60 Hz	m <sup>3</sup> /h	118/ 142	150/ 180	175/ 210	205/ 246	237/ 284	286/ 343	318/ 382	341/ 409	402/ 482	445/ 534	510/ 612	562/ 674	600/ 720	700/ 840	860/ 1032	910 / 1092	1000 / 1200	1100 / 1320	
Weight	Kg	325	330	335	510	515	585	590	595	730	740	775	1070	1090	1020	1020	1300	1300	1300	
Oil charge	dm <sup>3</sup>	6	6	6	7	7	10	10	10	14	14	16	19	19	20	23	25	25	25	
Crankcase heater		230V-200W-50/60Hz									230V-275W-50/60Hz									
Discharge line, internal Ø	mm/ "	42 / 1 5/8"	42 / 1 5/8"	42 / 1 5/8"	54 / 2 1/8"	54 / 2 1/8"	54 / 2 1/8"	54 / 2 1/8"	54 / 2 1/8"	80 / 3 1/8"	80 / 3 1/8"	80 / 3 1/8"	80 / 3 1/8"	80 / 3 1/8"	80 / 3 1/8"	80 / 3 1/8"	104,8 / 4"1/8	104,8 / 4"1/8	104,8 / 4"1/8	
Suction line, internal Ø	mm/ "	54 / 2 1/8"	54 / 2 1/8"	54 / 2 1/8"	67 / 2 1/8"	67 / 2 1/8"	80 / 3 1/8"	80 / 3 1/8"	80 / 3 1/8"	92 / 3 5/8"	92 / 3 5/8"	92 / 3 5/8"	104,8 / 4 1/8"	104,8 / 4 1/8"	104,8 / 4 1/8"	104,8 / 4 1/8"	125 / 5 1/4"	125 / 5 1/4"	125 / 5 1/4"	
Capacity control steps		For XS: STEP: 100,75,50									For RS3: STEP: 100,75,50%, minimum capacity; STEPLESS: from minimum capacity to 100% or from 50 to 100% - on demand									
Protection devices		INT 69 B2 (Standard) INT 69 SNY (Optional)															INT 69 SNY			
Lubricants		Refer to Table 2																		

Table 17: technical data

## 8 Dimensional drawings and packaging

### 8.1 Dimensional drawings

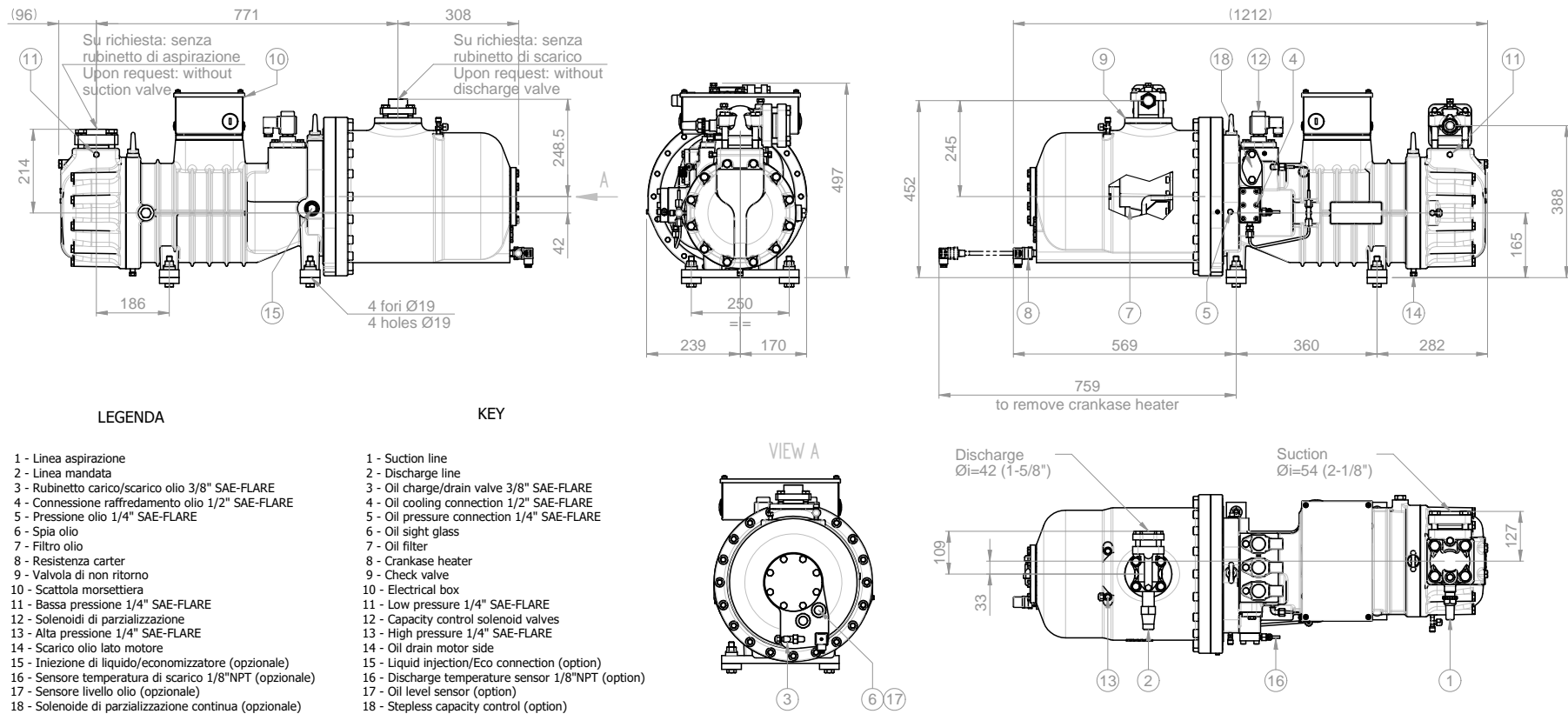
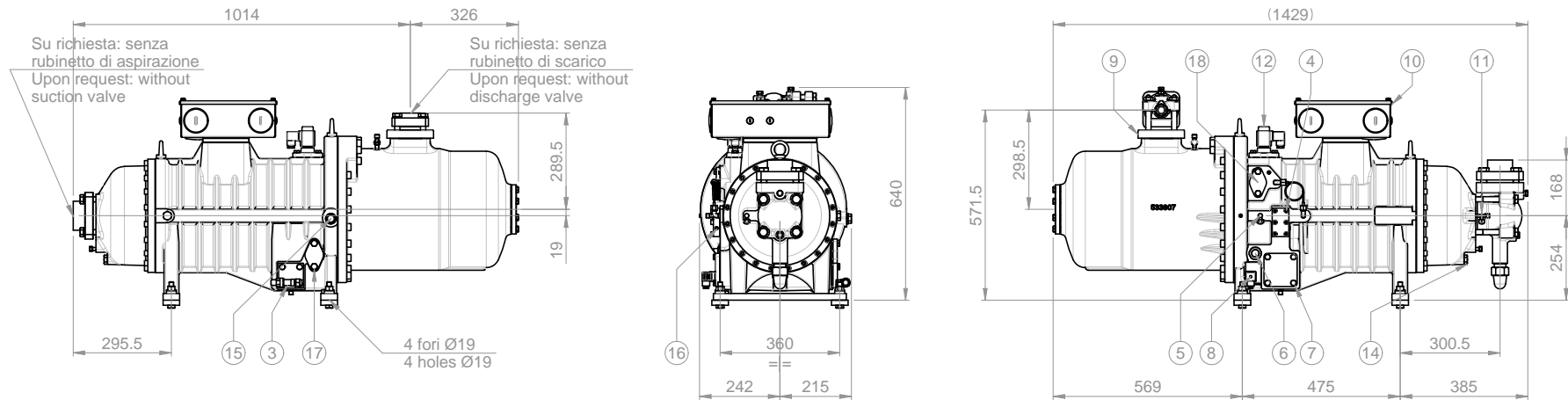

Fig. 44: dimensional drawing of the models: RS3-H040÷060/L030÷050 (drawing code: MSI007 r.05);



LEGENDA

- 1 - Linea aspirazione
- 2 - Linea mandata
- 3 - Rubinetto carico/scarico olio 3/8" SAE-FLARE
- 4 - Connessione raffreddamento olio 1/2" SAE-FLARE
- 5 - Pressione olio 1/4" SAE-FLARE
- 6 - Spia olio
- 7 - Filtro olio
- 8 - Resistenza carter
- 9 - Valvola di non ritorno
- 10 - Scattola morsetteria
- 11 - Bassa pressione 1/4" SAE-FLARE
- 12 - Solenoidi di parzializzazione
- 13 - Alta pressione 1/4" SAE-FLARE
- 14 - Scarico olio lato motore
- 15 - Iniezione di liquido/economizzatore (opzionale)
- 16 - Sensore temperatura di scarico 1/8"NPT (opzionale)
- 17 - Sensore livello olio (opzionale)
- 18 - Solenoide di parzializzazione continua (opzionale)

KEY

- 1 - Suction line
- 2 - Discharge line
- 3 - Oil charge/drain valve 3/8" SAE-FLARE
- 4 - Oil cooling connection 1/2" SAE-FLARE
- 5 - Oil pressure connection 1/4" SAE-FLARE
- 6 - Oil sight glass
- 7 - Oil filter
- 8 - Crankcase heater
- 9 - Check valve
- 10 - Electrical box
- 11 - Low pressure 1/4" SAE-FLARE
- 12 - Capacity control solenoid valves
- 13 - High pressure 1/4" SAE-FLARE
- 14 - Oil drain motor side
- 15 - Liquid injection/Eco connection (option)
- 16 - Discharge temperature sensor 1/8"NPT (option)
- 17 - Oil level sensor (option)
- 18 - Steplless capacity control (option)

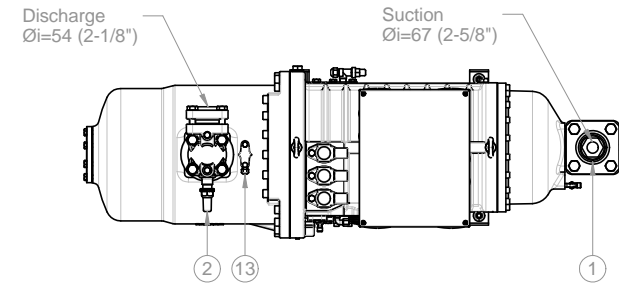
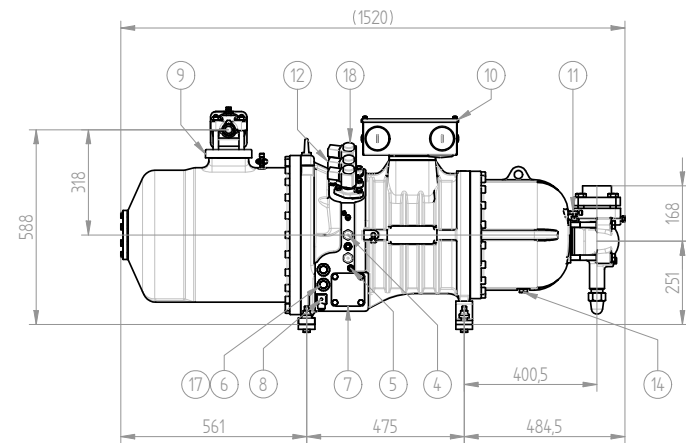
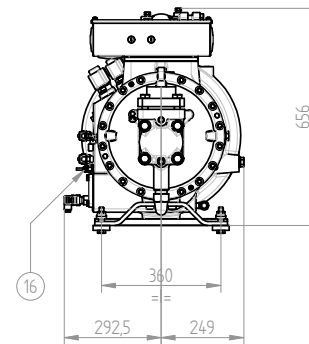
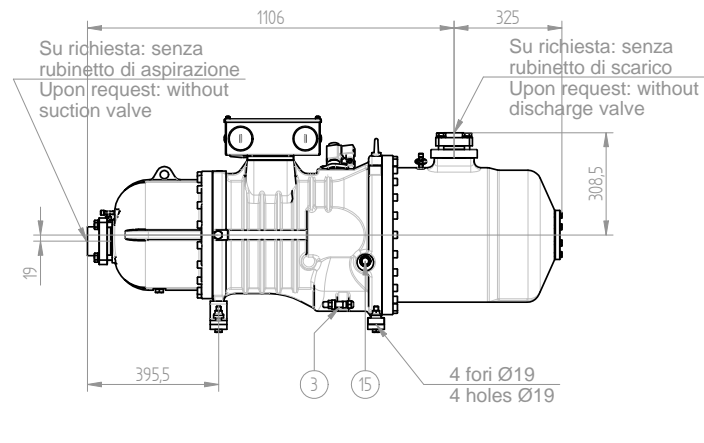

Fig. 45: dimensional drawing of the models: RS3-205-070/237-080 (drawing code: MSI014 r.05);



#### LEGENDA

- 1 - Linea aspirazione
- 2 - Linea mandata
- 3 - Rubinetto carico/scarico olio 3/8" SAE-FLARE
- 4 - Connessione raffreddamento olio 1/2" SAE-FLARE
- 5 - Pressione olio 1/4" SAE-FLARE
- 6 - Spia olio
- 7 - Filtro olio
- 8 - Resistenza carter
- 9 - Valvola di non ritorno
- 10 - Scattola morsettiera
- 11 - Bassa pressione 1/4" SAE-FLARE
- 12 - Solenoidi di parzializzazione
- 13 - Alta pressione 1/4" SAE-FLARE
- 14 - Scarico olio lato motore
- 15 - Iniezione di liquido/economizzatore (opzionale)
- 16 - Sensore temperatura di scarico 1/8"NPT (opzionale)
- 17 - Sensore livello olio (opzionale)
- 18 - Solenoide di parzializzazione continua (opzionale)

#### KEY

- 1 - Suction line
- 2 - Discharge line
- 3 - Oil charge/drain valve 3/8" SAE-FLARE
- 4 - Oil cooling connection 1/2" SAE-FLARE
- 5 - Oil pressure connection 1/4" SAE-FLARE
- 6 - Oil sight glass
- 7 - Oil filter
- 8 - Crankcase heater
- 9 - Check valve
- 10 - Electrical box
- 11 - Low pressure 1/4" SAE-FLARE
- 12 - Capacity control solenoid valves
- 13 - High pressure 1/4" SAE-FLARE
- 14 - Oil drain motor side
- 15 - Liquid injection/Eco connection (option)
- 16 - Discharge temperature sensor 1/8"NPT (option)
- 17 - Oil level sensor (option)
- 18 - Steplless capacity control (option)

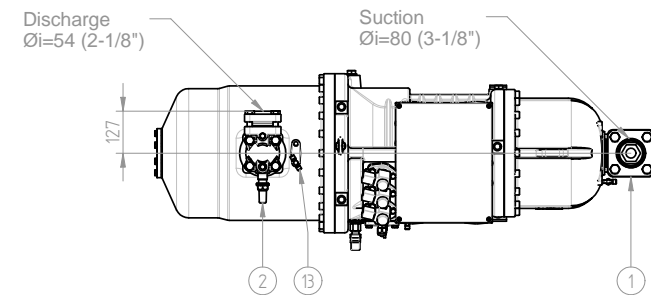
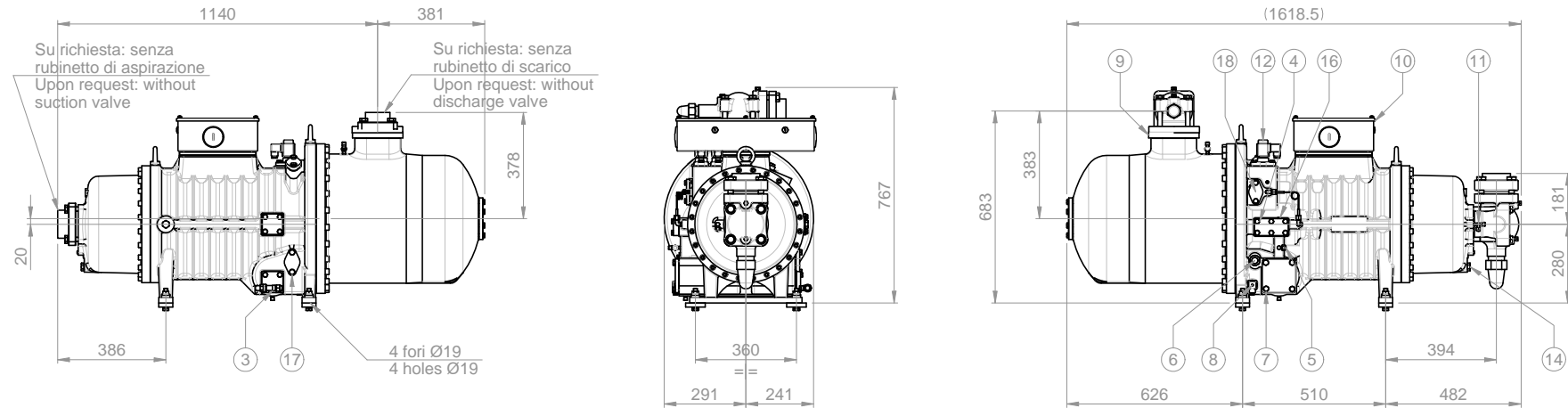

Fig. 46: dimensional drawing of the models: RS3-286-100/318-110/341-120 (drawing code: MSI037 r.02);



LEGENDA

- 1 - Linea aspirazione
- 2 - Linea mandata
- 3 - Rubinetto carico/scarico olio 3/8" SAE-FLARE
- 4 - Connessione raffreddamento olio 1/2" SAE-FLARE
- 5 - Pressione olio 1/4" SAE-FLARE
- 6 - Spia olio
- 7 - Filtro olio
- 8 - Resistenza carter
- 9 - Valvola di non ritorno
- 10 - Scattola morsetti
- 11 - Bassa pressione 1/4" SAE-FLARE
- 12 - Solenoidi di parzializzazione
- 13 - Alta pressione 1/4" SAE-FLARE
- 14 - Scarico olio lato motore
- 15 - Iniezione di liquido/economizzatore (opzionale)
- 16 - Sensore temperatura di scarico 1/8"NPT (opzionale)
- 17 - Sensore livello olio (opzionale)
- 18 - Solenoide di parzializzazione continua (opzionale)

KEY

- 1 - Suction line
- 2 - Discharge line
- 3 - Oil charge/drain valve 3/8" SAE-FLARE
- 4 - Oil cooling connection 1/2" SAE-FLARE
- 5 - Oil pressure connection 1/4" SAE-FLARE
- 6 - Oil sight glass
- 7 - Oil filter
- 8 - Crankcase heater
- 9 - Check valve
- 10 - Electrical box
- 11 - Low pressure 1/4" SAE-FLARE
- 12 - Capacity control solenoid valves
- 13 - High pressure 1/4" SAE-FLARE
- 14 - Oil drain motor side
- 15 - Liquid injection/Eco connection (option)
- 16 - Discharge temperature sensor 1/8"NPT (option)
- 17 - Oil level sensor (option)
- 18 - Steplless capacity control (option)

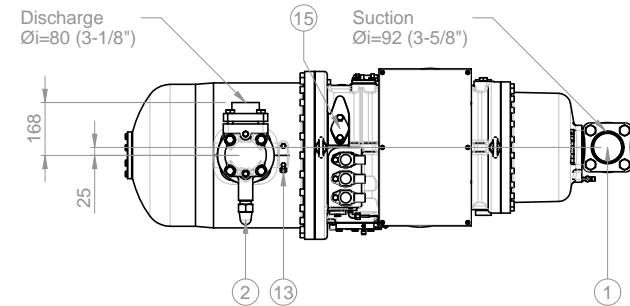
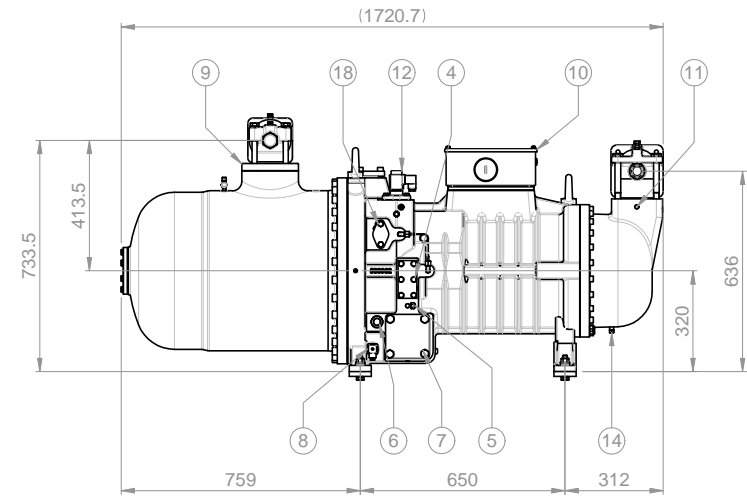
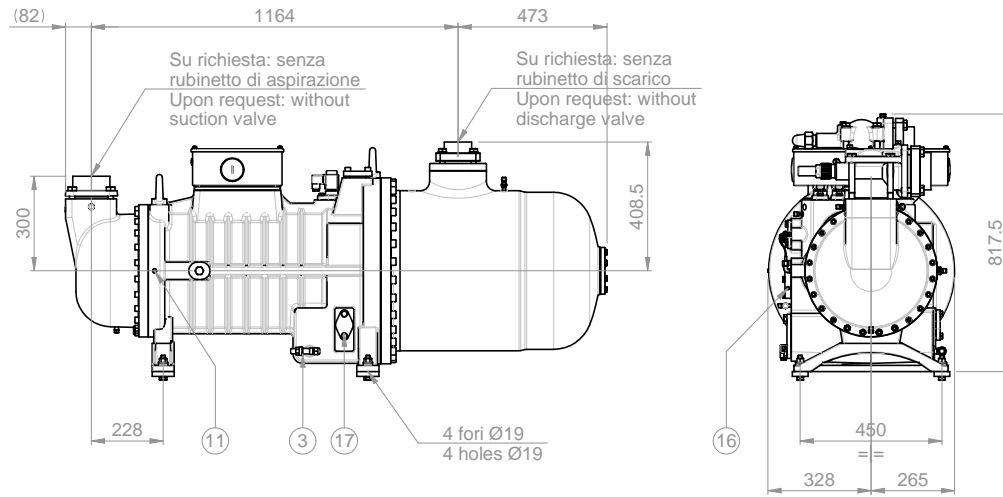

Fig. 47: dimensional drawing of the models: RS3-402-140/445-160/510-180 (drawing code: MSI001 r.10);





LEGENDA

- 1 - Linea aspirazione
- 2 - Linea mandata
- 3 - Rubinetto carico/scarico olio 3/8" SAE-FLARE
- 4 - Connessione raffreddamento olio 1/2" SAE-FLARE
- 5 - Pressione olio 1/4" SAE-FLARE
- 6 - Spia olio
- 7 - Filtro olio
- 8 - Resistenza carter
- 9 - Valvola di non ritorno
- 10 - Scattola morsetteria
- 11 - Bassa pressione 1/4" SAE-FLARE
- 12 - Solenoidi di parzializzazione
- 13 - Alta pressione 1/4" SAE-FLARE
- 14 - Scarico olio lato motore
- 15 - Iniezione di liquido/economizzatore (opzionale)
- 16 - Sensore temperatura di scarico 1/8"NPT (opzionale)
- 17 - Sensore livello olio (opzionale)
- 18 - Solenoide di parzializzazione continua (opzionale)

KEY

- 1 - Suction line
- 2 - Discharge line
- 3 - Oil charge/drain valve 3/8" SAE-FLARE
- 4 - Oil cooling connection 1/2" SAE-FLARE
- 5 - Oil pressure connection 1/4" SAE-FLARE
- 6 - Oil sight glass
- 7 - Oil filter
- 8 - Crankcase heater
- 9 - Check valve
- 10 - Electrical box
- 11 - Low pressure 1/4" SAE-FLARE
- 12 - Capacity control solenoid valves
- 13 - High pressure 1/4" SAE-FLARE
- 14 - Oil drain motor side
- 15 - Liquid injection/Eco connection (option)
- 16 - Discharge temperature sensor 1/8"NPT (option)
- 17 - Oil level sensor (option)
- 18 - Stepless capacity control (option)

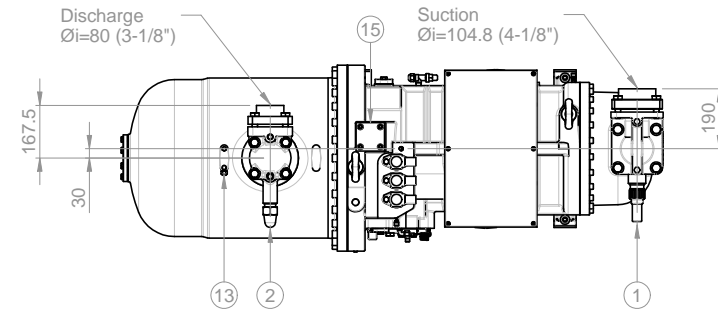

Fig. 48: dimensional drawing of the models: RS3-562-200/600-220/700-240 (drawing code: MSI025 r.05);

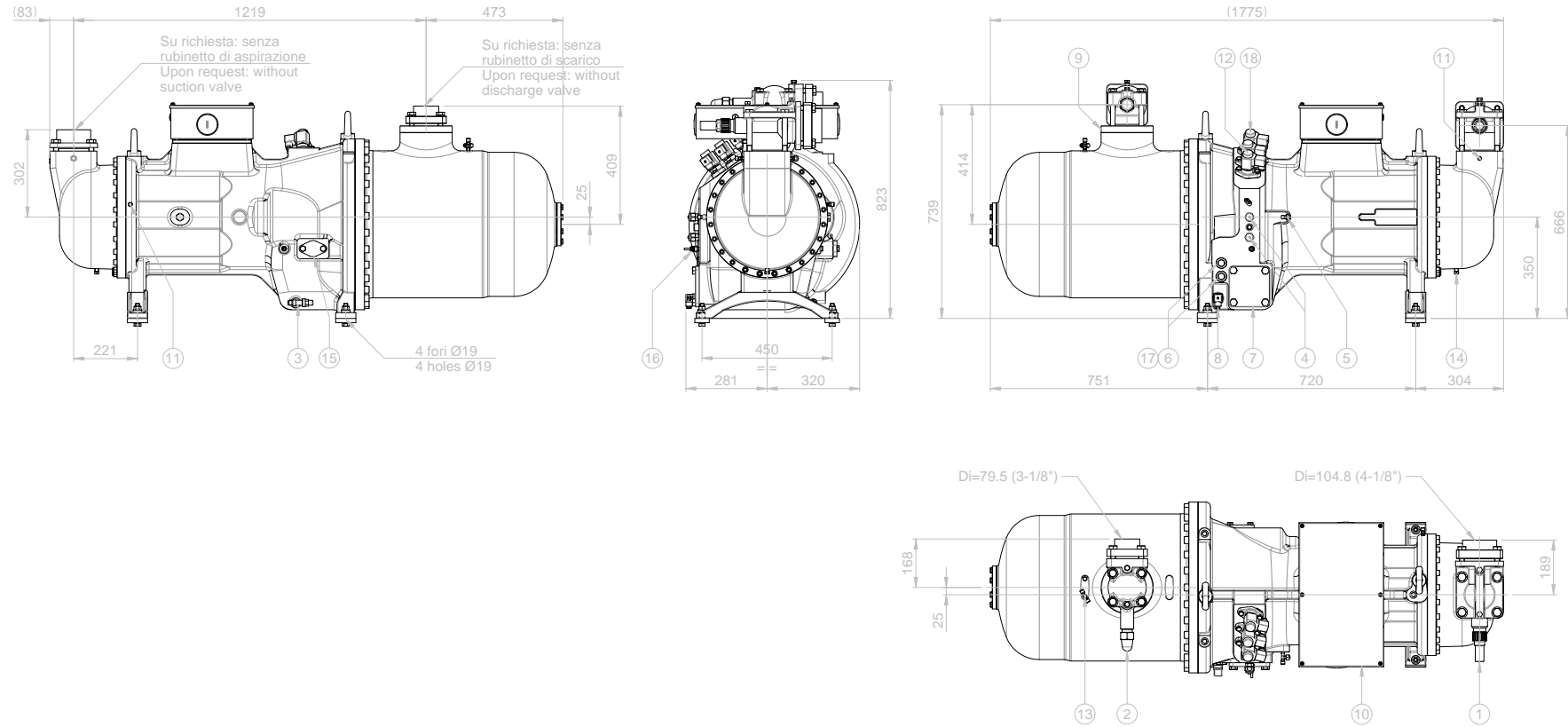

Fig. 49: dimensioni RS3-860-270 (MSI080 r.00);

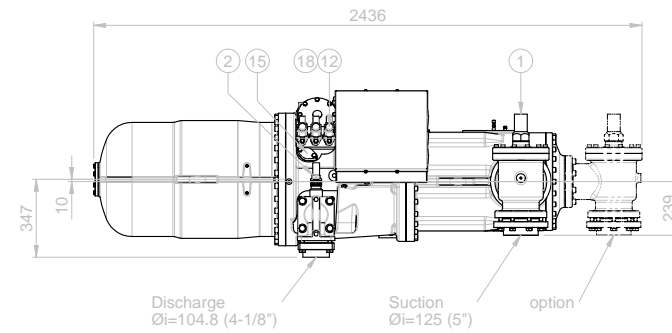
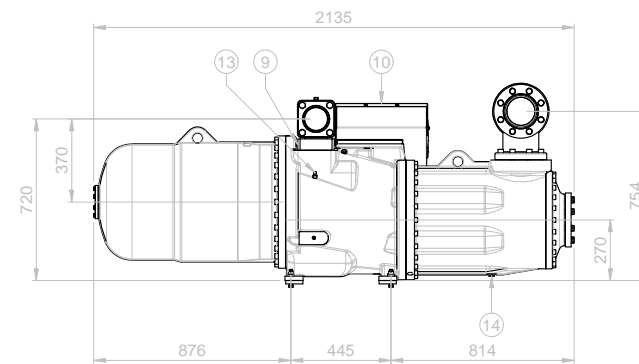
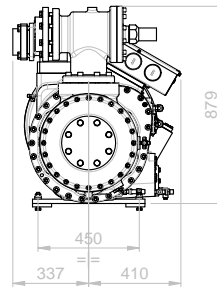
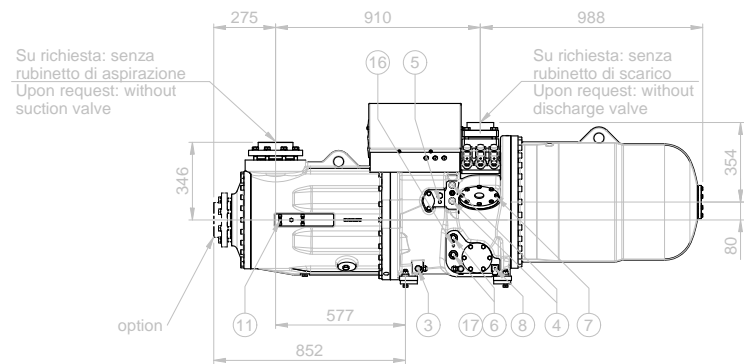

Fig. 50: DIMENSIONS PER RS3-910-300/1000-350/1100-390 (MSI061 R.03)

## 9 Transport, Handling and Storage

### 9.1 Receiving and unpacking

In order to protect and avoid damages during transport, the compressor is usually placed on a wooden pallet, fixed by screws, and a cardboard cover.

All the informations/pictograms required for shipping are printed on the package.

Upon receipt of the compressor, after removing the upper part of the package, make sure that no damage occurred during transport. If you notice damage due to transport, please provide to make a written complaint, possibly accompanied with photos of the damaged parts, to your insurance company and send copies to the Manufacturer and transporter. For the entire period that the compressor is not used, before unpacking it, store in a dry place at a temperature between + 5 ° C and + 45 ° C and in position to avoid contact with atmospheric agents.

For the entire period that the compressor is not used, after being unpacked, before first start-up or for long period unused, you need to change the oil and check the operation.

If the compressor is not used for long periods, you need to change the oil and check the operation.



**Please dispose of the packaging according to the different types of material in full compliance with the legislation in force in the country of use.**

### 9.2 Package dimensions:

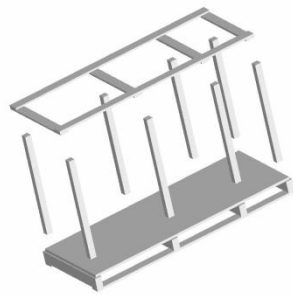

Internal packaging structure with cardboard walls

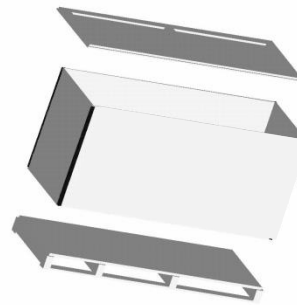

Packaging with wooden wall

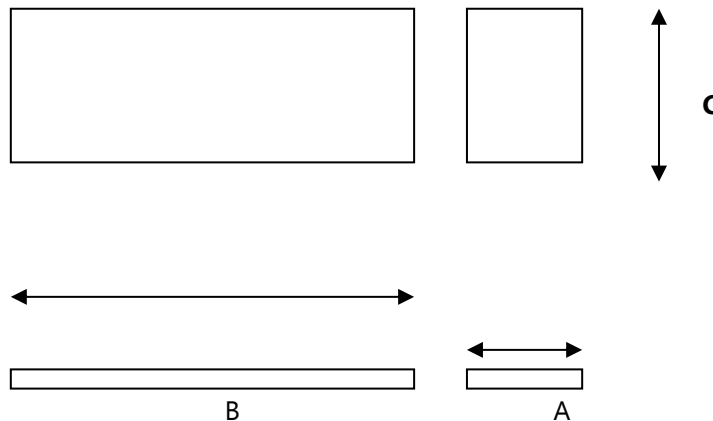

Models	A [mm]	B [mm]	C [mm] Wooden packing	C [mm] Carton packing
RS3-H040÷060/L030÷050	470	1320	675	702
RS3-H070÷120/L060÷100	590	1580	840	872
RS3-H140÷240/L110÷200	720	1860	1015	1052
RS3-H270/L220	720	1860	1010	1063
RS3-H300÷390/L240÷300	800	2170	1060	1050

Table 18: Packing dimensions (mm);

### 9.3 Transport & Handling



The transport of the packed compressor must be operated by qualified personnel using a forklift truck.



**ATTENTION** : before making any transport operation, make sure that the lift capacity is suitable for the load to be lifted.

Place the forks exclusively in the pallet bottom. After positioning the forks at the points indicated, lift slowly without sudden movements.



With the usage of a forklift, bring the compressor as close as possible to the place to install, then carefully remove the protective packing, paying attention not to damage it, and follow the instructions below:

- Remove the carton.
- Remove the screws that fix compressor to the wooden pallet.



Please dispose of the packaging according to the different types of material in full compliance with current legislation in the country of utilization.



It is mandatory to install the compressor in a ventilated area with proper ventilation to keep the room temperature between +2°C to +40°C, with humidity level between 5 to 95%.

It is mandatory to contact the manufacturer or authorized dealer in the event of an inadequate exhaust of hot air from the place of installation of the compressor.

It is mandatory that the air introduced into the compressor installation site is clean and free of dust, fumes and flammable vapors.

## 9.4 Compressor lifting

The compressor has to be lifted using the eyebolts of the same.

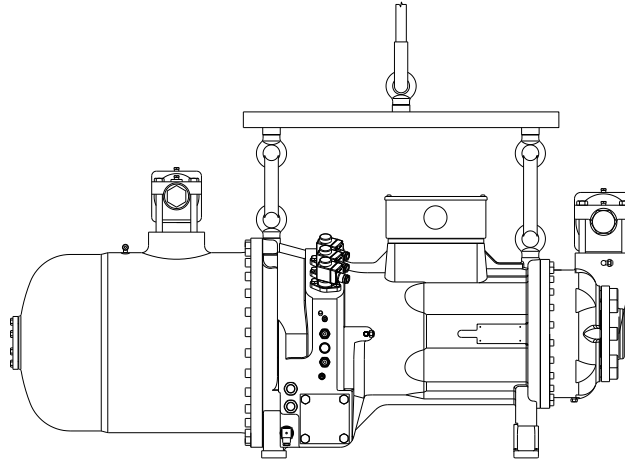

Fig. 51: anchor points for lifting the compressor;



The compressor can be transported by securing it to a pallet or alternatively lifting it with a suitable cross-beam, using the anchor points highlighted in Fig. 51.

Please check the capacity of the lifting crane according to the weight indicated in table below:

RS3	H040 L030	H050 L040	H060 L050	H070 L060	H080 L070	H100 L080	H110 L090	H120 L100	H140 L120	H160 L140	H180 L150	H200 L160	H220 L180	H240 L200	H270 L220	H300 L240	H350 L270	H390 L300
Weight [kg]	325	330	335	510	515	585	590	595	730	740	775	1070	1090	1020	980	1040	1350	1390

Table 19: Compressor weight

## 10 Performance data for the RS3 series compressors



In order to have performance data for conditions different than those as given above, use SRMTec selection program (contact SRMTec to have the updated software version):

SRMTec Software 1.9.6 - [Selezione1]

File Strumenti Finestra ?

Selezione1

Condizioni di progetto

Refrigeranti: R1234ze  
Serie: RS3 Ver.: ALL  
Modelli: ALL

Operating Conditions

Te dew: 2.00 °C Pe: 2.33 bar  
Tc dew: 40.00 °C Pc: 7.67 bar  
SC: 5.00 K Sottoraffreddamento liquido  
SHc: 10.00 K Surriscaldamento gas aspirazione

Circuit Options

Economizzatore: Non Calcolare  
Raffreddamento: Automatico

EL Motor options

Tensione del motore: 400 V 50 Hz (tensione standard)  
Taglia motore: Standard

Capacity control

Tipo controllo: Pieno carico

(F5) Calcola

Compressore	Qe(kW)	Pn(kW)	COP0	CA(A)	Qc(kW)	m(kg/h)	EER(0)	Qcooler(kW)	Td(°C)	Qd(kW)	IIP(bar)
R1234ze (VI=2.2)											
RS3-H040	65.8	19.1	3.45	34.7	83	1615.3	11.754	0	61.1	2.3	-
RS3-H050	75.3	21.9	3.44	38.3	95	1846.8	11.732	0	62.0	2.3	-
RS3-H060	81.4	23.7	3.43	49.5	103	1997.9	11.719	0	62.2	2.3	-
RS3-H070	99.0	28.3	3.50	49.1	125	2428.9	11.936	0	61.8	2.7	-
RS3-H080	110.1	31.2	3.53	69.2	139	2701.5	12.040	0	61.8	2.7	-
RS3-H100	132.7	37.5	3.54	75.5	167	3257.3	12.074	0	61.4	3.5	-
RS3-H110	147.7	41.8	3.53	80.0	186	3624.8	12.056	0	61.9	3.5	-
RS3-H120	157.5	44.7	3.52	83.8	199	3864.0	12.022	0	62.2	3.5	-
RS3-H140	184.9	51.8	3.57	88.3	232	4837.3	12.179	0	61.2	4.7	-
RS3-H160	208.0	57.8	3.60	96.0	261	5104.4	12.278	0	61.3	4.7	-
RS3-H180	233.3	64.7	3.61	118.2	293	5725.9	12.303	0	61.6	4.7	-
RS3-H200	262.3	72.8	3.60	125.1	331	6435.7	12.294	0	62.4	3.7	-
RS3-H220	289.2	80.2	3.61	144.0	366	7097.4	12.304	0	62.6	3.7	-
RS3-H240	319.3	88.6	3.60	155.0	404	7834.7	12.296	0	62.8	3.7	-
RS3-H270	388.0	121.3	3.20	200.2	503	9521.5	10.914	0	67.1	6.2	-

Messaggi | Dati tecnici | Polinomi | Dimensione | Limiti

**RS3-H140**

Portata a 50/60 Hz [m<sup>3</sup> / h] **402 / 482**  
 Peso (kg) **730**  
 Carica olio [dm<sup>3</sup>] **14**  
 Connessione di scarico int. [Mm / "] **80 / 3 1/8"**  
 Connessione di aspirazione int. [mm / "] **92 / 3 5/8"**  
 Tipo avviamento **Star Delta (SD)**  
 Taglia motore **Standard (Small)**  
 Motore **400/3/50**  
 L.R.A. [A] **354/1155**  
 Fla [A] **225**

Programma di selezione SRMTec.

Performance data are obtained through measurements made at the suction and discharge connection.

See chapter 8: "Dimensional drawing and packaging" for connection positions on each models.

According to the chapter 11: "Application range", the following tables highlight the working condition which require the monitoring of the filter pressure drop (see chapter 3) or the additional cooling (see chapter 12);

For all the refrigerant mixtures the above mentioned temperatures are the DEW ones.

The performances are optimized for the following working conditions:

- Gas suction overheating: SH=10K;
- Liquid sub-cooling: SC=5K;
- Three-phase electrical net frequency: f=50Hz;
- Nominal voltage: V=400V;
- Working conditions without ECONomiser circuit.

Key:

Te: Evaporating temperature [° C];

Tc: Condensing temperature [° C];

Qe: Refrigerant power [kW];

Pta: Absorbed power [kW];

# 11 Application range

## 11.1 General

The normal admissible operating conditions for the RS3 series compressors, with changes in evaporation and condensing temperature, are defined by a polygon, as highlighted in Fig. 52.

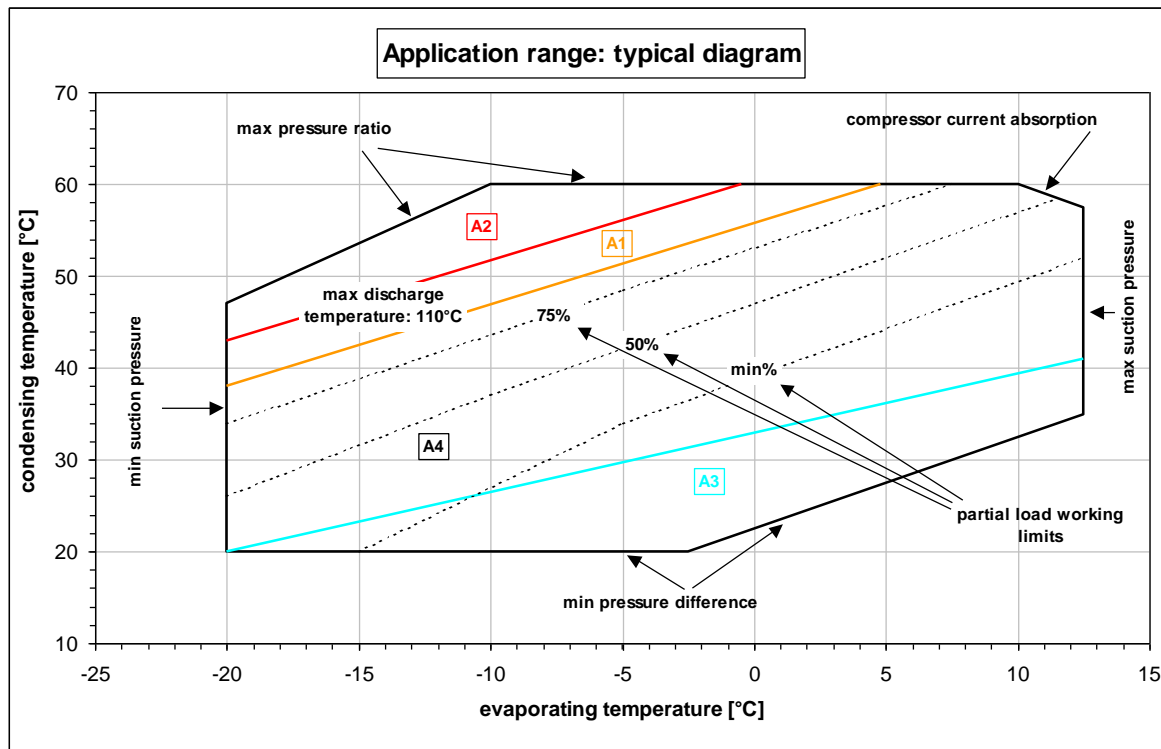

Fig. 52: typical application range;

The entire field of operation of the compressor is divided into four areas, featuring special precautions that must be adopted so as to ensure correct operation; specifically:

- Area A1: area in which the correct operation of the compressor requires additional cooling by the injection of liquid (refrigerant) or cooling of the oil in an external circuit (air-oil, water-oil and refrigerant-oil heat exchangers), see chapter 12 Additional cooling;
- Area A2: area in which additional cooling must be provided only by cooling the oil. Use air-oil or water-oil exchangers (the injection of liquid into the compressor is not allowed), see chapter 12 Additional cooling;
- Area A3: area in which the status of the oil filter needs to be monitored: the pressure drop allowed across the filter must be less than 1.5 bar; if the pressure drop across the filter is greater than 1.5 bar, the compressor must be stopped and the filter replaced. When the filter has been replaced, check the condition of the new filter after around 200-300 hours of operation. The pressure drop across a clean filter is less than 0.8 bar, see chapter 3: "Lubrication";
- Area A4: area of standard compressor operation;

In addition to the above given areas, the diagram gives also, as dotted lines, the working limits on partial load: 75%, 50% and min%. For each partial load, these lines limit the maximum possible condensation temperature in relation to the evaporation temperature.

Because of the several refrigerants available, please refer to the official SRMTec selection software for specific details.



## 12 Additional cooling

### 12.1 Admissible compressor discharge temperature

The value of the discharge temperature is determined by the following factors:

- ✓ power input of the compressor and any part-load conditions, which determine a drop in the cooling capacity of the electric motor;
- ✓ actual cycle working compression ratio;
- ✓ superheating of the refrigerant fluid on the suction side;
- ✓ characteristics of the refrigerant gas, such as the thermal capacity;
- ✓ characteristics of the oil mixed with the refrigerant.

An excessive discharge temperature can cause:

- ✓ the carbonisation and permanent alteration of the oil;
- ✓ a reduction in the oil cinematic viscosity, with a consequent drop in the lubrication capacity and reduction in the volumetric efficiency of the compressor;

Excessive cooling of the oil, on the other hand, may cause, as well as a high pressure drop in the oil circuit, the excessive dilution of the oil by the refrigerant, and consequently:

- ✓ an alteration in the flow of lubricant inside the compressor;
- ✓ a reduction in the lubricating properties;
- ✓ the bypass of refrigerant fluid to the suction side (through the oil circuit), which has undergone the compression process but will not produce the cooling effect.

The maximum admissible discharge temperature is 110 °C while, when the compressor is off, the minimum temperature of the oil before starting is 40°C.

Below is described how to evaluate the additional cooling capacity when the oil needs to be cooled, and the possible ways to provide it. As regards the heating of the oil, on the other hand, see paragraph 3.6: 'Oil heater' in chapter 3: "*Lubrication*".

### 12.2 Evaluating the additional cooling capacity

When the discharge temperature exceeds 110°C, an additional cooling system is required. The additional cooling capacity required to perform such cooling can be calculated by multiplying the mass flow in the evaporator by the difference between the enthalpy at the discharge without additional cooling and the enthalpy at the discharge pressure when the temperature is 110°C (the enthalpy values should be read on the refrigerant chart).

When calculating the required cooling capacity, the most critical normal operating conditions should be considered (minimum evaporation temperature, maximum condensing temperature, maximum superheat). Alternatively, the calculation can be performed automatically using the SRMTec selection program.

As a result, depending on the additional cooling capacity to be provided, there are two possible methods to limit the compressor discharge temperature:

- ✓ Cooling by injection of refrigerant (liquid) onto the rotors. It is taken from the condenser outlet and subsequently expanded;
- ✓ Cooling of the oil in a circuit external to the compressor. It can be used either an oil-air, or an oil-water, or an oil-refrigerant heat exchanger.

The following pages describe the two above-mentioned methods of cooling.

### 12.3 Injection of liquid by thermostatic expansion valve

A relatively simple and economical system for additional cooling consists in the injection of refrigerant (saturated liquid) at intermediate pressure onto the rotors, as seen in the diagram of Fig. 53<sup>5</sup>. The liquid is injected through the economizer port and allows the operating limits to be extended, see chapter 11: 'Application range.

When the required additional cooling capacity exceeds a certain percentage of the compressor cooling capacity, the use of this method would entail an excessive quantity of refrigerant and bring about its dilution in the oil, with a consequent loss in the oil lubricating properties, as well as an excessive overloading of the motor. In this situation, the oil should be cooled in an external circuit with a heat exchanger, see the following paragraph. The operating limits shown in chapter 11 highlight the normal operating conditions in which cooling by injection is admissible, and the conditions where an external oil cooler is required.

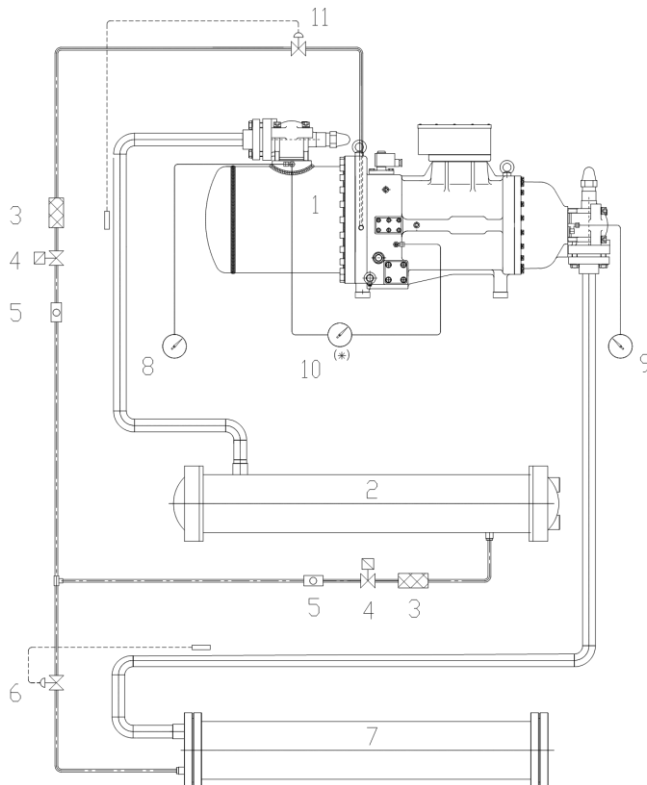

- 1 Compressor;
- 2 Condenser;
- 3 Filter;
- 4 Solenoid valve;
- 5 Sight glass;
- 6 Thermostatic expansion valve;
- 7 Evaporator;
- 8 HP pressure gauge (high pressure);
- 9 LP pressure gauge (Low pressure);
- 10 Differential pressure gauge on the oil filter;
- 11 Thermostatic injection valve.

Fig. 53: injection of refrigerant (saturated liquid) via thermostatic expansion valve; To inject the refrigerant into the compressor, an expansion device must be installed; this may be:

- ✓ a thermostatic expansion valve;
- ✓ a calibrated nozzle;
- ✓ a capillary tube.

If a thermostatic valve is used, the expansion can be controlled accurately. In this case, the quantity of refrigerant injected varies according to the actual temperature measured at the discharge side of the compressor.

The thermostatic valve should be set to be activated at discharge temperatures of 100-110°C (manufacturers such as Danfoss, Alco and Sporlan provide such products).



**Note:**

- ✓ **for the correct sizing of the thermostatic valve according to the specific application, contact your valve supplier;**

<sup>5</sup> This is simply a schematic drawing; refer to the dimensional drawing for each individual compressor to identify the actual position of the liquid injection port and the high and low pressure connections.

- ✓ the use of liquid injection is not recommended when the required additional cooling capacity reaches values of around 10% of the cooling capacity of the compressor;
- ✓ the use of liquid injection together with the ECONOMIZER circuit is strongly not recommended.

The thermostatic valve bulb must be positioned on the discharge line around 10-20 cm from the discharge shut-off valve; it must be thermally insulated so as to not be affected by the outside temperature, and the contact with the discharge pipe must be improved by using conductive paste. Attach the bulb securely. Make sure only saturated liquid or sub-cooled liquid is tapped from the line. Once the injection circuit has been constructed, check that there are no dangerous vibrations in the section of pipe that runs from the valve to the point of injection.

To prevent the migration of oil and protect the components against liquid-oil slugging, the injection pipe must initially run vertically, starting from the point of injection, see the picture Fig. 54<sup>6</sup>.

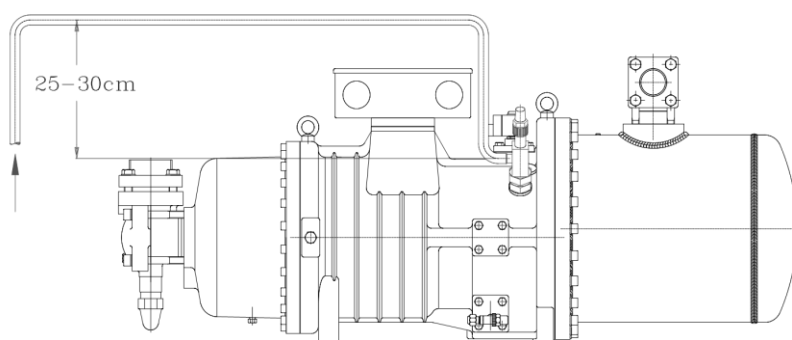

Fig. 54: layout of the liquid injection line;

The valve should not be oversized, so as to avoid the injection of an excessive quantity of liquid. When sizing, the injection pressure must be considered, intermediate between the evaporation and condensing pressure. This can be determined using the SRMTec selection program.

Together with the expansion device, the injection circuit must be fitted with a solenoid valve, a thermostat (or equivalent device) positioned on the discharge, a sight glass and a fine mesh filter (max 25  $\mu\text{m}$ ) to avoid the injection of metallic particles onto the rotors that may affect the correct operation and the life of the compressor.

The thermostat on the discharge line will activate the injection circuit when the discharge temperature exceeds the value of 110°C, while it will be de-activated when the discharge temperature drops below 100-105°C.

The compressor should have an injection fitting (special accessory available upon request); the diameter of the injection pipe is determined according to Table 20 below.

RS3	H040 L030	H050 L040	H060 L050	H070 L060	H080 L070	H100 L080	H110 L090	H120 L100	H140 L120	H160 L140	H180 L150	H200 L160	H220 L180	H240 L200	H270 L220	H300 L240	H350 L270	H390 L300
D [mm]	16						22			42			28					

Table 20: injection pipe diameter;

For the injection of the liquid, use the following kit suggested for each model and available as optional

<sup>6</sup> This is just a schematic drawing: please refer to the specific compressor dimensional drawing in order to locate the actual position for the liquid injection port.

## 12.4 Oil cooling via external heat exchanger

In comparison with the previous cooling method this one allows a further extension of the application limits of the compressor (see chapter 11: '*Application limits*') and a more efficient operation. In fact, cooling improves the volumetric and isentropic efficiency of the compression, thus increasing the coefficient of performance of the refrigerating cycle.

For this purpose, the compressor has special oil outlet and inlet fittings (on the internal oil circuit) for connection to the external cooling circuit, see paragraph 12.5. The diameter of the pipes in the circuit is 16 mm for all models in the RS3 series.

Using an external circuit increases the compressor oil requirement. In this case, the oil charge in the compressor must be suitably increased according to the type of cooling circuit used. Specifically you must consider:

$$\begin{aligned} \text{TOTAL OIL CHARGE} &= \text{COMPRESSOR CHARGE} \\ &+ \text{HEAT EXCHANGER CHARGE} \\ &+ \text{VOLUME OF OIL PIPES} \\ &+ 1\% \text{ OF REFRIGERANT CHARGE} \end{aligned}$$



### ATTENTION!

the pressure drop in the external oil cooling circuit must not exceed 0.5 bar.

- Air cooled oil cooler

The oil cooler (finned coil) must be installed as near as possible to the compressor, so that the pressure drop in the circuit does not exceed 0.5 bar in normal conditions. The cooling system with fans must be controlled by a temperature sensor positioned on the compressor discharge line, set at 110°C; the control logic may be ON-OFF or variable speed.

To ensure the rapid heating of the oil when starting (so as to reduce the high pressure drop with cold oil), the cooler should be heated during standstill periods, or the cooler can be bypassed using a modulating 3 way valve until the discharge temperature reaches 100°C. This is especially recommended when the temperature of the cooler, during standstill periods, may drop below 40°C, or when the volume of oil in the cooler and in the pipes exceeds 25 dm<sup>3</sup>

- Water cooled oil cooler

The oil-water heat exchanger can be supplied with condensed water or chilled water. The water supply can be modulated by a two-way valve with the temperature sensor on the compressor discharge pipe (set at 110°C) or alternatively, as highlighted in picture 11-C7, a modulating three-way valve can be used, with the temperature sensor positioned on the oil pipe leaving the compressor.

---

<sup>7</sup> This is simply a schematic drawing; refer to the drawings of each compressor shown in the paragraph 11-5 for details on the oil fittings.

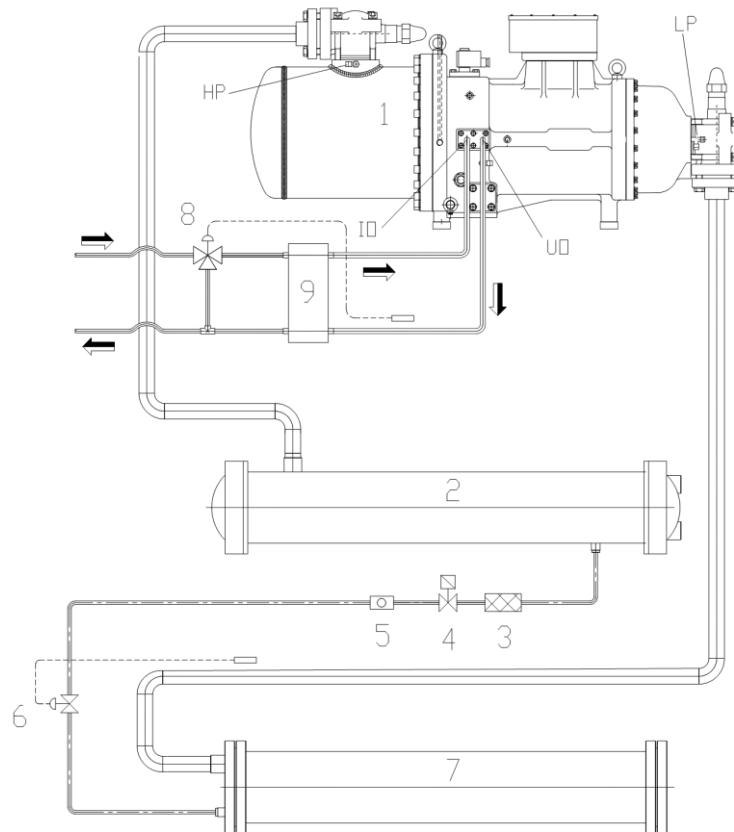

Fig. 55: oil cooling with oil/water heat exchanger

1	Compressor	7	Evaporator
2	Condenser	8	Modulating 3-way water valve
3	Filter	9	Oil/water heat exchanger
4	Solenoid valve		
5	Sight glass	IO	oil inlet
6	Thermostatic valve	UO	oil outlet

- Refrigerant fluid cooled oil cooler

Fig. 56<sup>8</sup> shows the diagram of a refrigerant circuit in which the oil is cooled by the refrigerant. An expansion valve controls the flow of refrigerant that cools the oil in the heat exchanger. The oil-refrigerant exchanger must be suitable for the high differences in temperature between the two fluids.

<sup>8</sup> This is simply a schematic drawing; refer to the drawings of each compressor shown in the paragraph 11-5 for details on the oil fittings and shown in chapter SA-08 in order to locate the actual position for the liquid injection port.

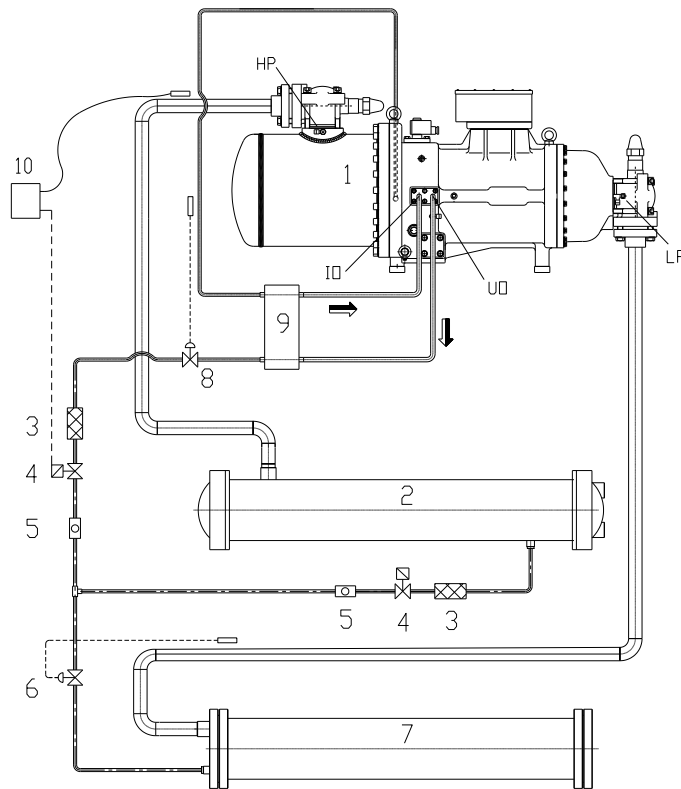

Fig. 56: oil cooling with oil/refrigerant fluid heat exchanger

1	Compressor	7	Evaporator
2	Condenser	8	Oil cooling expansion valve
3	Filter	9	Oil/water heat exchanger
4	Solenoid valve	10	Thermostat
5	Sight glass	IO	oil inlet
6	Thermostatic valve	UO	oil outlet

For any further information about this oil cooling method, please contact SRMTec.

## 12.5 Position of the oil inlet-outlet connections

As regards the oil inlet-outlet connections, distinction needs to be made between the new-concept models and the remaining models in the RS3 series.

### 12.5.1 RS3-H100/110/120, H270/300/350/390, L080/090/100, L220/240/270/300

To connect the oil cooler, the internal lubrication circuit needs to be modified, changing some parts of the compressor, as shown in Fig. 57 below.

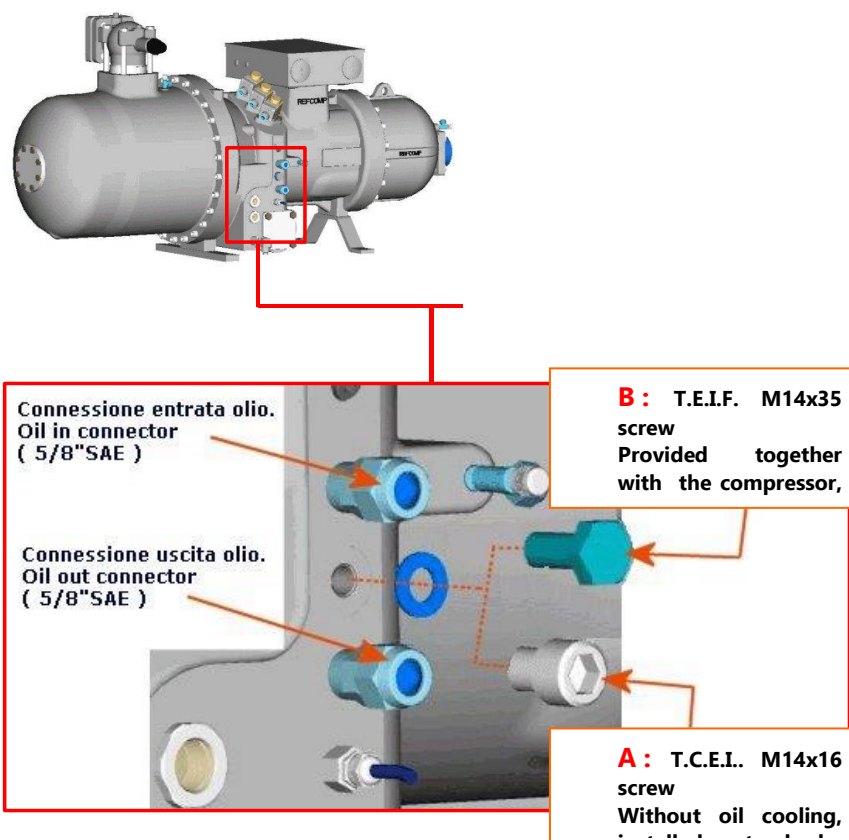

Fig. 57: oil inlet/outlet connection location for the external oil cooling circuit;

In Fig. 57 the part subjected to modification is shown.

The compressor is delivered, in the standard version, with screw A: M14 x 16 fitted on the compressor; in this configuration, the compressor works without the oil cooler. Screw B: M14 x 35 is sent with the compressor, is not fitted and is placed in the electrical box.

In these models, to fit the oil cooler simply replace screw A with screw B and connect the pipes, without needing to use special kits, as is the case with the remaining models in the RS3 series.

### 12.5.2 RS3-H040/050/060, L060/070

In these models, to make the connection to the cooling circuit, a plate must be replaced, using the kit shown in the next page.

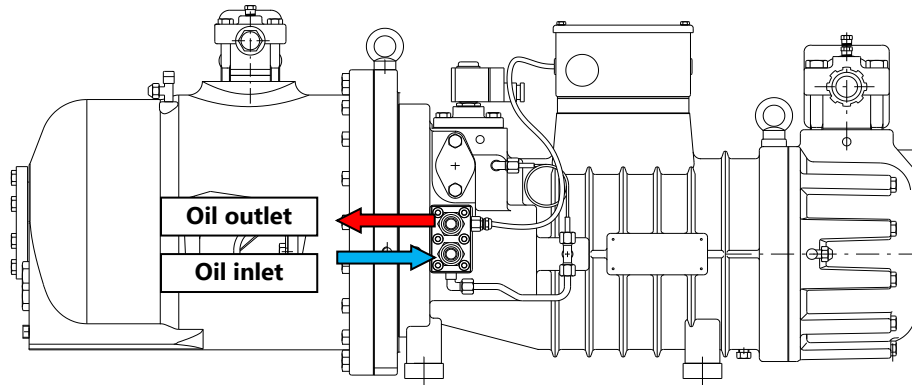

Fig. 58: Models RS3-H040÷060/L030÷050

### 12.5.3 RS3-H070/080, L060/070

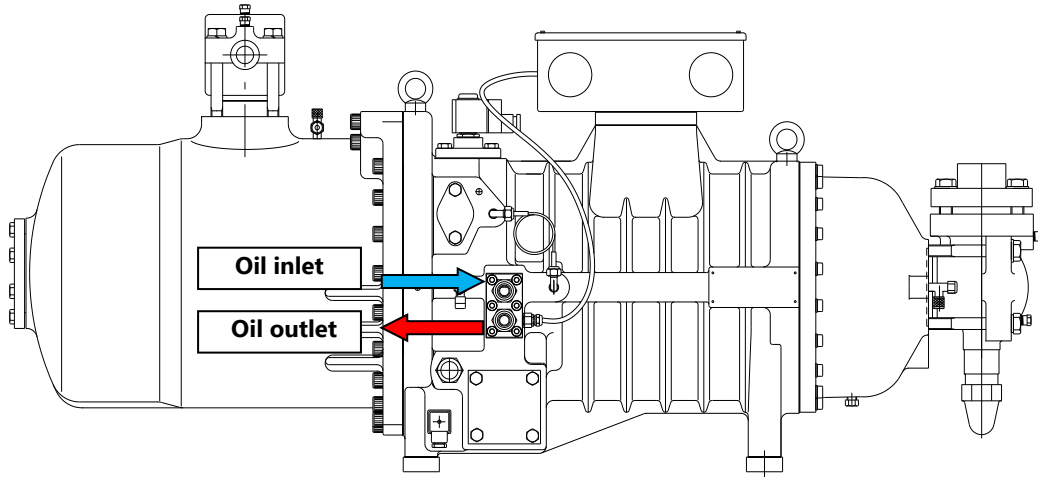

Fig. 59: Models RS3-H070/080



#### 12.5.4 RS3-H140/160/180/200/220/240, L110/120/140/160/180/200

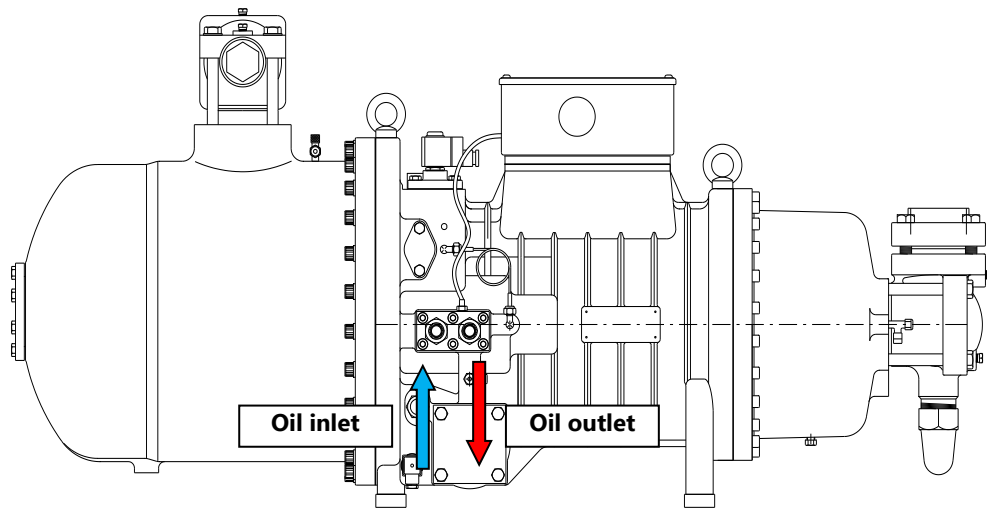

Fig. 60: Models RS3-H140÷240/L110÷200

## 13 Operative instruction

### 13.1 Ambient operating and storage temperature

The temperature of the environment where the compressor operates and is stored must be between -15°C and +50°C.

### 13.2 Suction superheat

Because of the lubricant solubility with refrigerants, the design, operation mode and control of the compressor and the system are subject to particular requirements.

Low or insufficient superheat in operation and insufficient heating or the oil sump during shut-off periods lead to a substantial reduction of the oil viscosity in the compressor.

This results in reduced performance, heavy wear on drive gear parts, increased oil carryover and foaming into the oil separator.

Secure the compressor against wet operations and guarantee a sufficiently high suction gas temperature.



#### ATTENTION!

**The discharge gas temperature must be at least 10K above the condensing temperature!**



Preferred use of heat exchanger between liquid line and suction gas line in order to rise the suction superheat at approx. 7K at system design conditions.

### 13.3 Pressure specifications

The compressor has the following pressure specifications:

- ✓ Maximum operating pressure: 27.5 bar high pressure side;
- ✓ Maximum balanced pressure: 19 bar high and low pressure sides.

Never operate the compressor at a higher pressure than the maximum operating pressure specified by SRMTEC and indicated on its plate. The user must ensure also that the balanced pressure does not exceed the maximum value specified by SRMTEC.

To test the tightness of the compressor, proceed as follows:

- ✓ Test the tightness on low pressure side at 19 bar;
- ✓ Test the tightness on high pressure side at 30.2 bar.

The compressors are designed and tested according to the European standards EN 60335-2-34.

### 13.4 Balanced pressure when starting

In order to generate a starting torque greater than the resisting one, the balanced system pressure (pressure inside the compressor during standstill periods) must not exceed 19 bar.



#### Attention!

**The compressor has to start at minimum capacity step.**

### 13.5 Maximum ambient temperature

During operation, the temperature of the environment where the compressor is working must be kept below the maximum value of 50°C when using common refrigerants (ex. R22, R407C, R134a, R1234yf, R1234ze, R513a) and +40°C when using low temperature application refrigerants (ex. R404A, R507, R407F, etc).

If the compressor is installed in a soundproofed cabinet, suitable ventilation and temperature monitoring systems must be provided.

### 13.6 Number of start-ups

The compressor can be started a maximum of 6 times per hour (1 start every 10 minutes).



#### Attention!

**A number of starts higher than the one suggested may damage the electrical motor and affect the theoretical compressor working life.**

### 13.7 Starting, stopping and minimum running time

The compressor must operate for a minimum time of three minutes. In addition, it must be started and stopped at minimum capacity (minimum step). The transients at minimum load must last 25 seconds at least.

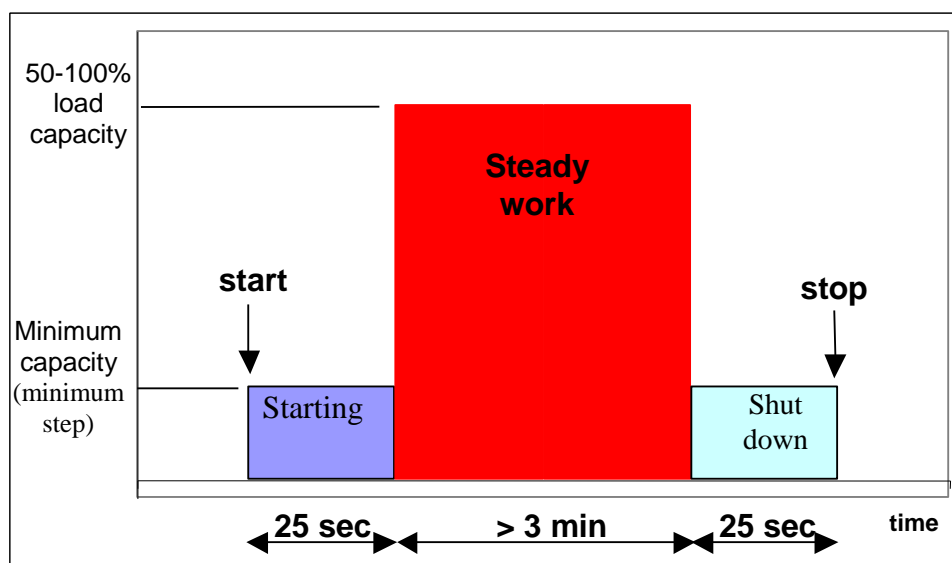

### 13.8 Installation

The compressor must be installed horizontally. To prevent the compressor from transmitting vibrations to the structure, the vibration damper kit should be used. It is supplied as an option. Flexible pipes are not required on the suction or discharge lines. Only minimum flexibility of the lines is required, so that these do not exert any force on the compressor.

Please use pipes and components that are extremely clean and dry inside, without slag, swarf, rust and phosphate coating.

When operating in extreme conditions, such as low ambient temperatures or aggressive atmospheres, suitable measures should be adopted. Please contact SRMTec.

## 13.9 Heat pumps

	<p><b>Warning!</b> Reverse cycle systems or hot gas defrosts require suitable measures to protect the compressor against:</p> <ul style="list-style-type: none"> <li>✓ Liquid slugging;</li> <li>✓ Increase in oil carry over, which determines a consequent decrease in the oil level inside the compressor;</li> <li>✓ Operation with a reduced <math>\Delta p</math> (HP-LP), and a consequent reduction in lubrication.</li> </ul>
---	--

To protect the compressor against liquid slugging, a suction accumulator should be installed. To prevent excessive oil carry over (due to a rapid decrease in pressure in the oil separator), make sure that the temperature of the oil during the reverse cycle procedure is at least 30-40 K above the condensing temperature. It may be necessary to install a pressure regulating valve downstream the compressor to limit the drop in pressure during reverse cycle and defrost operation. The compressor can also be stopped just before reversing the cycle and then started again after the pressure has balanced. In any case the compressor should work within the specified range of pressures and within the operating limits, as well as with the recommended protectors, within a maximum of 20 seconds from starting (see chapter 3: "Lubrication").

## 13.10 Testing

### 13.10.1 Leak testing/evacuation/oil charge

	<p><b>Note:</b> The compressors are supplied with a protective nitrogen charge (0.5-1 bar above atmospheric pressure) to prevent air from entering inside.</p>
---	--

Perform the leak test on the refrigerant circuit with dry nitrogen; if the circuit is tested with dry air, the compressor must be bypassed. Empty the entire circuit, including the compressor and the sections isolated by the valves, both on the suction side and on the discharge side. The vacuum required is at least 1.5 mbar (with isolated vacuum pump); if necessary, repeat the operation more than once. After emptying, add the oil to the compressor, if the oil charge is supplied separately, and switch on the oil heater.

As regards the compressor, this has already been tested for leaks under pressure, and therefore this test does not need to be performed by the user. If the leak test does need to be repeated by the user, make sure the design pressures reported on the compressor rating plate are never exceeded (see paragraph 13.3: "Pressure specifications").

	<p><b>Warning!</b></p> <ul style="list-style-type: none"> <li>➤ Never subject the compressor to pressure higher than the design values indicated on the rating plate;</li> <li>➤ Never start the compressor under vacuum.</li> </ul>
---	--

### 13.10.2 Refrigerant charge



Charge the liquid refrigerant directly into the receiver and into the condenser, and complete the charge on the suction side during operation.

To avoid liquid backflow when the refrigerant is charged in the liquid phase (verify that the discharge temperature is around 20K above the condensing temperature).

An insufficient charge causes a low suction pressure and a high superheat (observe the chapter 11: "Application limits").

To identify the correct discharge temperature, use the SRMTec selection software.

## 13.11 Starting

STARTING:

- ✓ After discharging the protective nitrogen charge, connect the compressor to the plant, making sure that the shut-off valves are closed. This avoids contact between the humidity of the air and the oil. However if the oil comes into contact with the humidity, it must be for not longer than 30 min;
- ✓ Make all the electrical connections as given in the wiring diagram on chapter 6.2.4: "Electrical devices";
- ✓ Perform the following preliminary checks:
  - ✓ Correct setting of the start timers;
  - ✓ Oil level;
  - ✓ Correct safety and protection devices setting and functioning;
  - ✓ Correct functioning of the high and low pressure switches;
  - ✓ Look for leakage along the piping and system components;
  - ✓ Turn on the oil heater at least 24 hours before each first seasonal start-up. The oil inside the separator must have a temperature at least 15K higher than the ambient temperature;
  - ✓ Charge the condenser with the minimum refrigerant charge;
  - ✓ Open the suction and discharge shut off valves and start the compressor while checking the correct motor rotation in the following way (even if some protection electronic device is used):
    - Connect a manometer on the suction port;
    - Start for 1 second max;
    - If the compressor screws rotate correctly, the suction pressure will drop promptly. The electronic protection intervention or a suction pressure increase implies the wrong rotors rotation. In this case, switch two of the power supply phases in the terminal plate.
    -



#### Warning!

To prevent severe damage of the compressor, a contingent screw inverse rotation should lasts for less than 3 sec.

START:

- ✓ Fill up the plant with the necessary amount of refrigerant;
- ✓ Re-start the compressor and open slowly the suction shut-off valve;
- ✓ Make sure that the oil level is visible through the sight glass. Presence of foam is normal as long as the working conditions are not stable. The discharge temperature must be about 20K higher than the condensing temperature;

- ✓ Check the correct intervention for the pressure switches;
- ✓ Check the working parameters (data logging is recommended):
  - Evaporating pressure;
  - Condensing temperature;
  - Suction gas temperature;
  - Discharge temperature;
  - Pressure drop through the oil filter;
  - Contingent unbalanced electrical absorbed currents on all the 6 wires connected to the electricity grid.
- ✓ Change the oil filter if dirty (see chapter 3: "*Lubrication*").

### 13.12 Protection devices intervention and trouble shooting

Failure	Protection devices	Why it is necessary	Delivery
Incorrect phase sequence	Phase monitor	The compressor should not work with inverse rotation	INT 69 SNY (optional)
High discharge pressure	Manual pressure switch	To avoid an excessive pressure increase in the compressor	necessary, not included
High temperature of motor windings	thermistors embedded in the motor windings (cut out 100/120° C)	To protect the motor from high temperatures	standard
Too high motor current	Thermal Relay	To protect motor from electrical overload	necessary, not included
Low suction pressure	pressure switch	insufficient refrigerant charge (high pressure ratio, high disch.temp.)	necessary, not included
Low differential pressure HP/LP	HP/LP differential pressure switch (cut out 4 bar min)	To grant a sufficient oil flow	necessary, not included
High oil discharge temperature	Additional cooling (liquid injection / oil cooling)	To ensure a long bearing life	mandatory if required by the working conditions
Lack of lubrication	discharge gas temperature sensor (cut out 120° C)	To protect the compressor from lack of lubrication	temperature sensor: optional with INT 69 B2 and standard with INT 69 SNY
Too high pressure drop in the oil filter	differential pressure switch (cut out 1.5 or 3.5 bar, see chapter 3 and 11)	To ensure cleanness of oil filter	necessary, not included
Too frequent compressor starts	limit of starts (max 6 per hour)	To protect the electrical motor	necessary, not included

## 14 Maintenance

### 14.1 Lubricants

The lubricants have high thermal and chemical stability: if installation is performed correctly, the oil normally does not need to be changed. Periodically test the acidity of the oil to prevent damage to the motor or the compressor and, if necessary, perform the following operations:

- ✓ clean the circuit placing an acid filter in the suction line;
- ✓ change the oil and the oil filter;
- ✓ purge the system from the highest point on the discharge side.

The oil can be drained through the service valve and the plug on the bottom of the suction cover (see chapter 3: "*Lubrication*"). The oil can be recharged through the service valve, creating a vacuum inside the compressor.

### 14.2 Bearings

The bearings in the compressor are designed to ensure 40,000 hours of operation with correct lubrication (oil filter clean and oil pressure within the limits, see paragraph SA-02: '*Lubrication*') and continuous load within the limits specified in chapter 11: "*Application range*". Any alteration of the above-mentioned conditions and excessive changeability of the load may bring a drastic reduction in the effective working life. The bearings must be replaced by qualified personnel in a specially equipped workshop.

### 14.3 Rotors rotation direction

If the reverse rotation, which occurs when the compressor stops to balance the pressure, lasts more than 3 seconds, the check valve located underneath the discharge shut-off valve may be damaged, and consequently must be replaced. In any case, the reverse rotation must not last more than 5 seconds to avoid damage to the compressor and the unwanted activation of the INT 69 SNY protection module.

### 14.4 Maintenance plan

On the table below, necessary check outs and maintenance operations are listed:

Time (h)	50-100	1000	10000	20000	30000	40000
Oil filter	I/R		I/R	I/R	I/R	R
Oil	I	I	I	I	I	R
Suction filter		I	I/R	I/R	I/R	I/R
Solenoid valves		I	I	I	I	I
Bearings					I	R
Check valve		I	I	I	I	I
INT module		I	I	I	I	I
Feeding voltage	I	I	I	I	I	I
Motor contactors		I	I	I	I	I

Table 21: maintenance plan: R = replace I = Inspect



## 15 Capacity control conversion

As already mentioned in chapter 4: "*Capacity control*", the conversion between step and stepless configurations is performed differently for the new-concept models RS3-H100/110/120 and the remaining models in the RS3 series. In the new three models, in fact, just one plate needs to be changed, while in the others one, the external capillary tube needs to be changed, suitable calibrated orifices have to be installed and the position of one of the three solenoid valves used for capacity control has to be changed. The procedures for the two types of RS3 series compressors are described separately.

	<p>Warning!</p> <ul style="list-style-type: none"> <li>✓ All the required operations to change the capacity control, must be done without pressure inside the compressor;</li> <li>✓ After the configuration change, the refrigerant is charged inside the compressor by setting the compressor on vacuum;</li> <li>✓ All operations must be carried out by expert personnel.</li> </ul>
---	--

### 15.1 RS3-H040÷080, H140÷240, L030÷070, L110÷200

#### 15.1.1 Conversion from STEP (L4) to INFINITE (LZ) capacity control

The special conversion kit (code 303184) is used to perform the conversion from the STEP to the INFINITE configuration.

The kit includes the following components:

- 1) N.4 GASKETS for the solenoid valves and cover flange, code 592731.

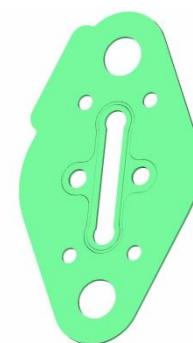

- 2) N.1 CAPILLARY TUBE, complete with lock nuts and rings, code 540684.  
*NOTE: the capillary tube installed in the "LZ" version is smaller than the tube used in the "L4" version.*

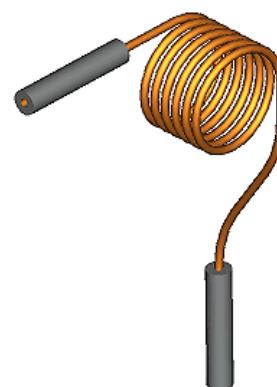

## 3) N.2 CALIBRATED ORIFICES, code 540711



With reference to the following pictures, the conversion from "L4" to "LZ" is achieved by changing the position of solenoid valve 16 with the cover flange located in position 19. In the LZ configuration, then, this solenoid valve is identified by number 19 and no longer by 16. In addition, you have to replace the capillary tube already installed on the compressor with the new one included in the conversion kit and you have to install the given calibrated orifices. The operating instructions are shown in the following pages.

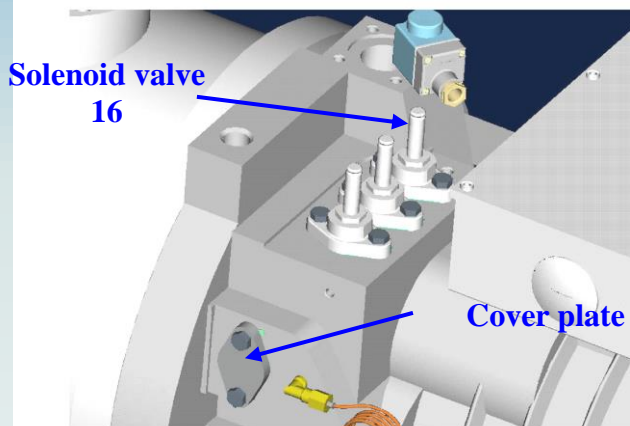

L4 configuration (step)

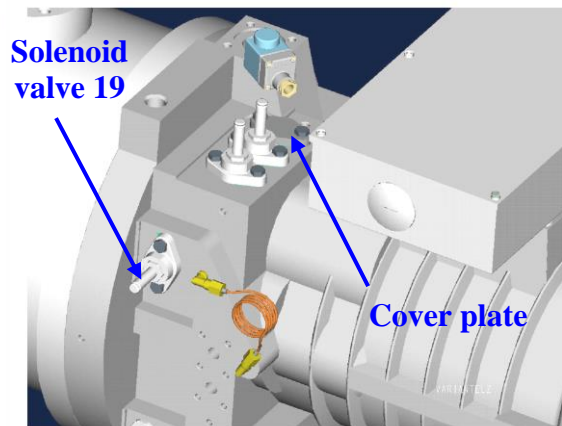

LZ configuration (stepless)

**Operating instructions:**

- 1- Remove solenoid valve 16 and the cover flange;
- 2- In place of solenoid valve 16, fit the cover flange inserting the gasket -code 592731- included in the conversion KIT;

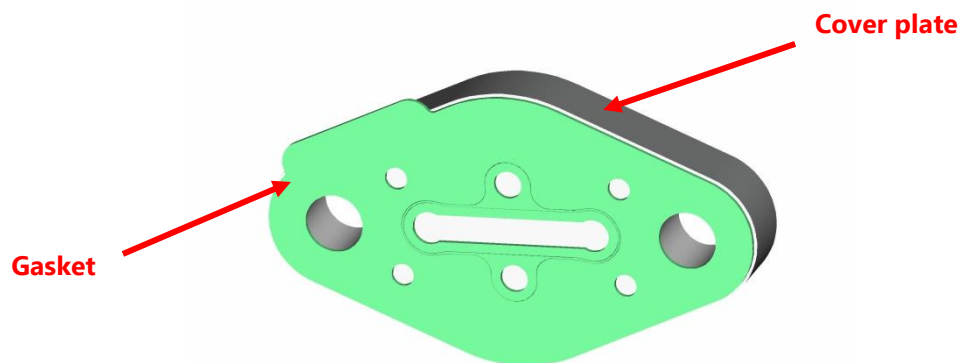

- 3- Fit the solenoid valve in the new position 19, with the inserted gasket -code 592731- included in the conversion KIT;

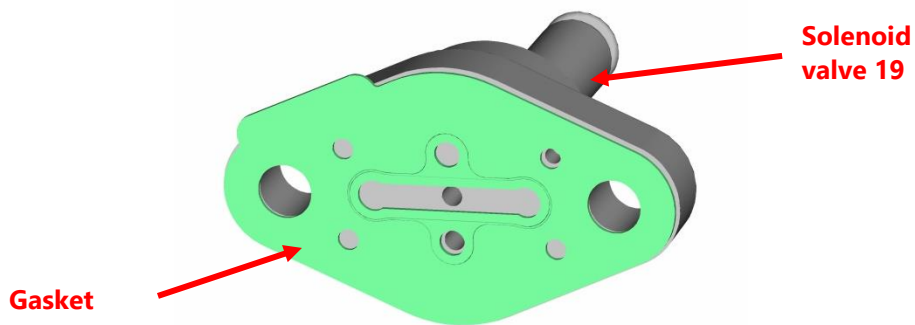

- 4- Remove solenoid valves 14 and 15 and tighten the two calibrated orifices to the casing;

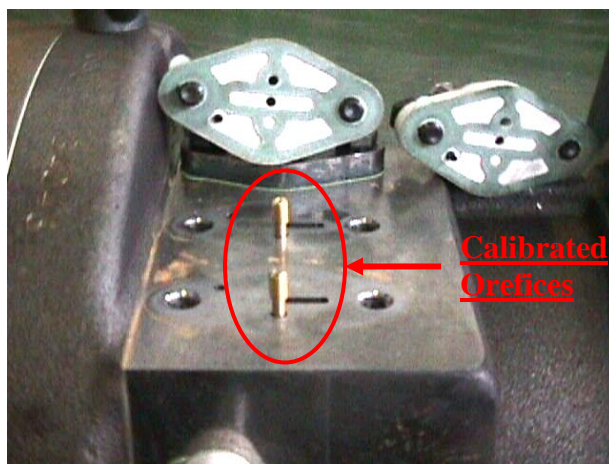

- 5- Replace solenoid valves 14 and 15 in the same position, inserting the gaskets -code 592731;

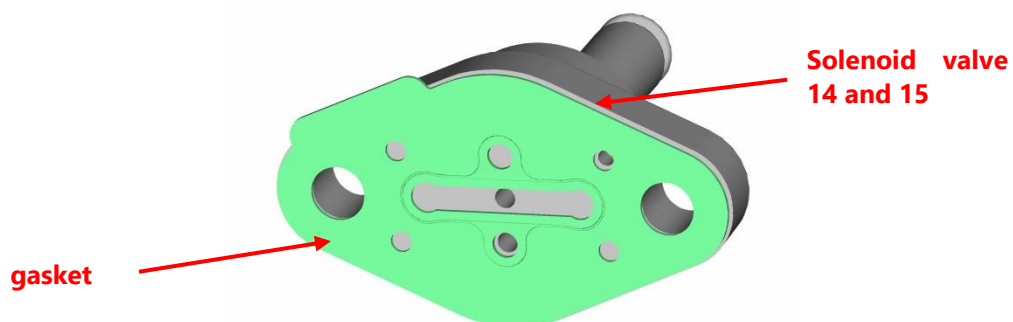

- 6- Replace the capillary tube with the new one -code 540684- included in the kit;

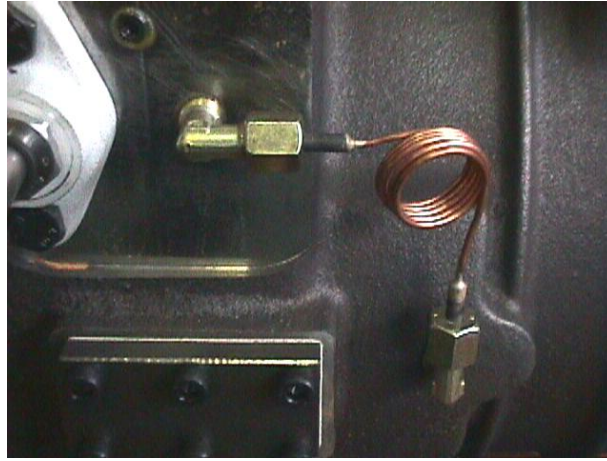

### 15.1.2 Conversion from INFINITE (LZ) to STEP (L4) capacity control

The special conversion kit (code 303202) is used to perform the conversion from the INFINITE to the STEP configuration.

The kit consists of the following components:

- 1) N.3 GASKETS for solenoid valves, code 592731

- 2) N.1 GASKET for solenoid valves, code 592732

- 3) N.1 CAPILLARY tube, complete with nuts, code 540701  
*NOTE: the capillary tube installed in the "L4" version is larger than the one used in the "LZ" version.*



With reference to the pictures of the following page, the conversion from "LZ" to "L4" is performed by changing the position of solenoid valve 19 with the cover flange, now located on top of the compressor, next to the other two solenoid valves. In the L4 configuration, therefore, this solenoid valve will be identified again by the number 16 and the cover flange will return to its original position (19) of the L4 configuration. In addition, replace the capillary tube already installed in the compressor with the new one included in the conversion kit and remove the calibrated orifices. The operating instructions are shown in the following page.

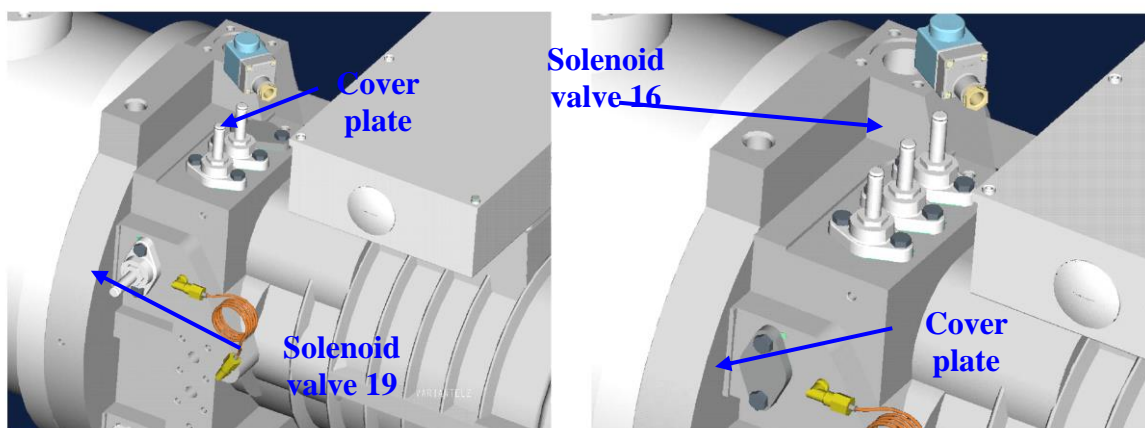

LZ configuration (stepless)

L4 configuration (step)

### Operating instructions:

1. Remove solenoid valve 19 and the cover flange;
2. In place of the cover flange, fit the solenoid valve after inserting the gasket -code 592731- included in the conversion kit;

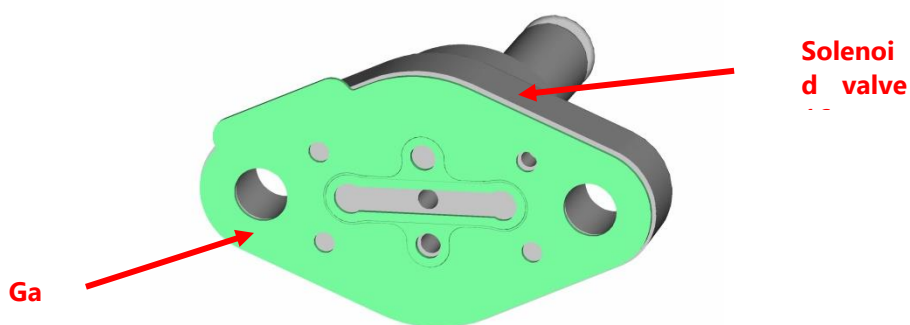

3. In the position 19 fit the cover flange, after inserting the gasket -code 592732- included in the conversion kit;

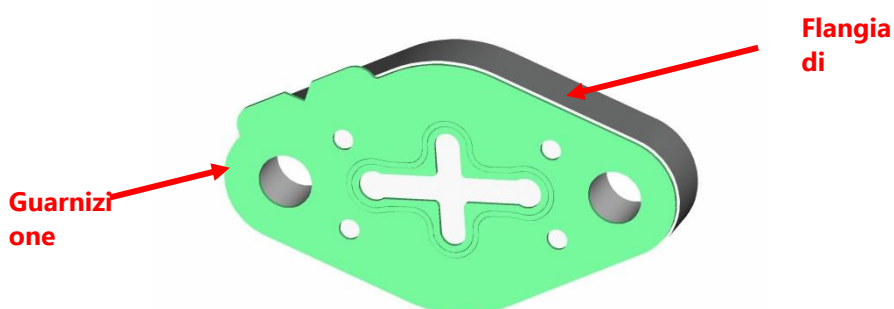

4. Remove the orifices positioned underneath the solenoid valves 14 and 15;



5. Replace the solenoid valves 14 and 15 in their original position, after inserting the gaskets -code 592731;

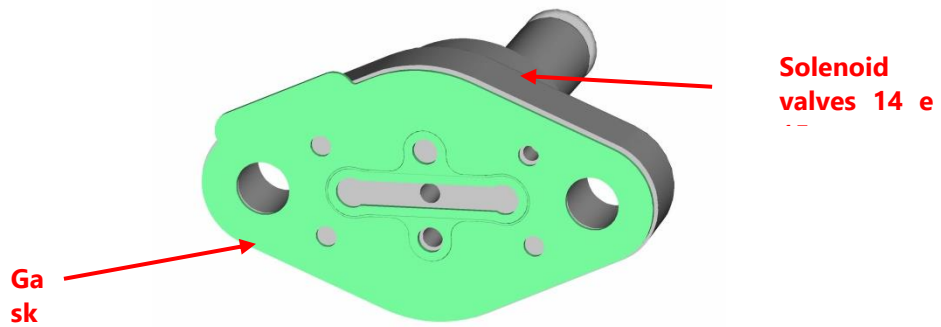

6. Change the capillary tube with the new one -code 540701- included in the conversion kit;



## 15.2 RS3-H100/110/120, H270, L080/090/100, L220

In the above specified models, the step and stepless configurations can be changed simply by using different special-shape plates, which modify the configuration of the internal oil circuit (see chapter 4: '*Capacity control*', paragraphs 4.2 and 4.3).

Below is a description of the conversion kits and their components.

KIT FOR CONVERTING FROM THE STEP TO THE STEPLESS CONFIGURATION: Code 303559.

Components:

- Code: 519423 "LZ" capacity control plate;
- Code: 585918 capacity control conversion diagram;
- Code: 592731 Solenoid valve gasket;
- Code: 592762 Solenoid valve gasket / capacity control plate;
- Code: 614566 Elastic pin d=3x8 DIN 7346 UNI 68;

KIT FOR CONVERTING FROM THE STEPLESS TO THE STEP CONFIGURATION: Code 303558.

Components:

- Code: 519422 "L4" capacity control plate;
- Code: 585918 capacity control conversion diagram;
- Code: 592731 Solenoid valve gasket;
- Code: 592762 Solenoid valve gasket / capacity control plate;
- Code: 614566 Elastic pin d=3x8 DIN 7346 UNI 68;

The following page reports the necessary instructions and the assembly diagram of the various components required to replace the two plates and perform the conversion.



**Attention:**

As shown in the following page, the two plates have a different external profile. This means that the type of the applied capacity control can be easily identified all the times.

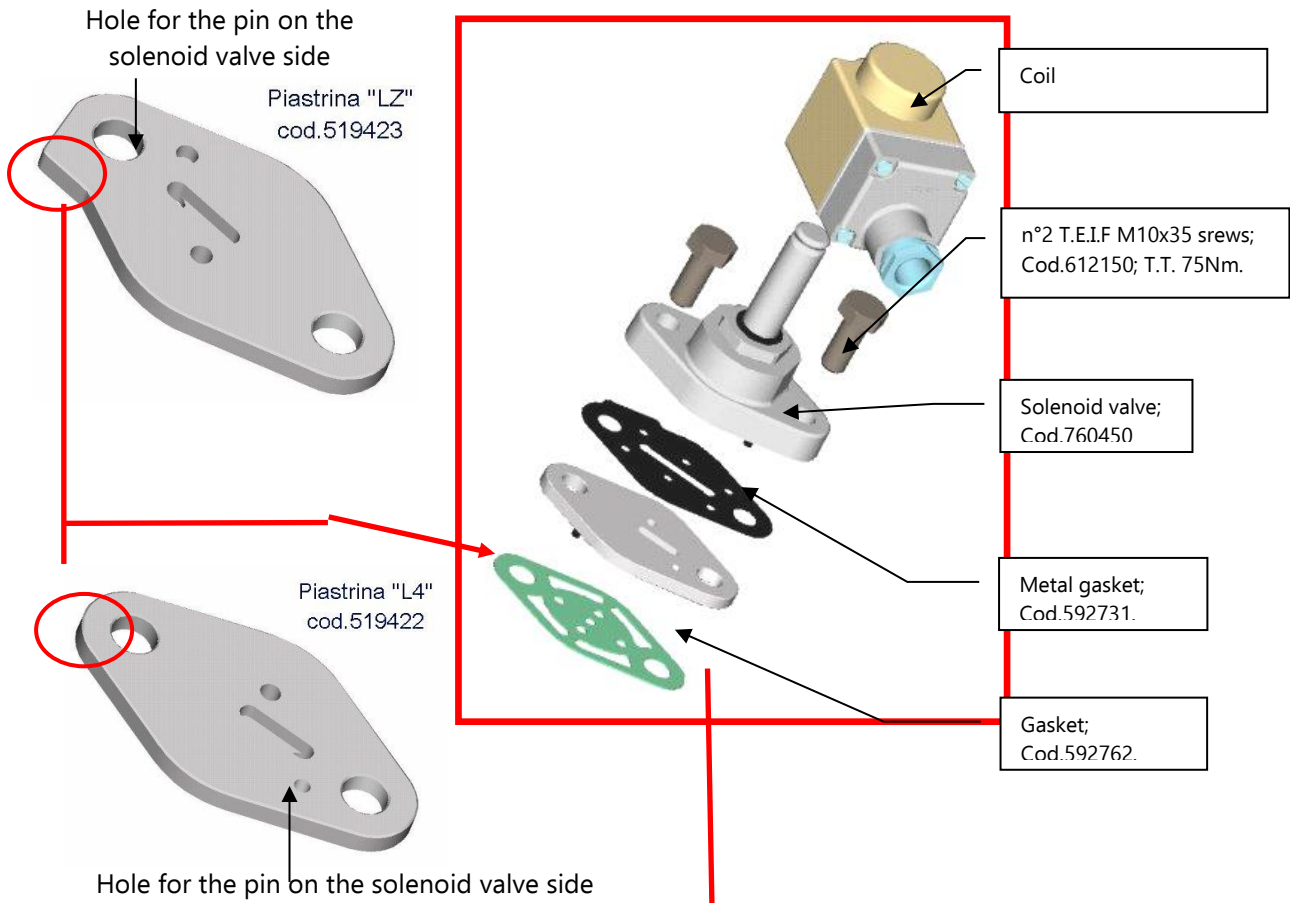

**Position of the plate: underneath the solenoid valve (16);**

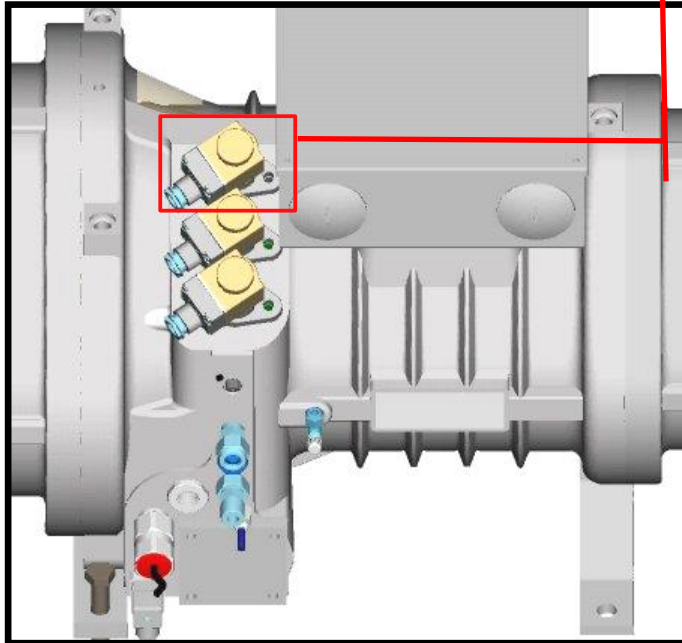

To convert the compressor lay-out from the stepped "L4" to the stepless "LZ" capacity control configuration, replace the plate code 519422 with the plate code 519423. Vice-versa you will perform the opposite switch.

**Notes:**

Please, install the electro-valve correctly by matching the base plate pin / case hole and electro-valve pin/base plate hole



### 15.3 RS3-H300/350/390, L240/270/300

Plate L4

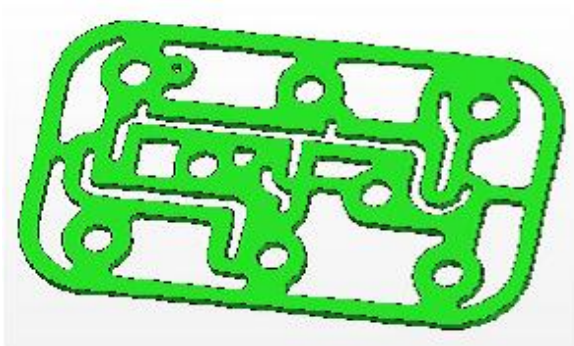
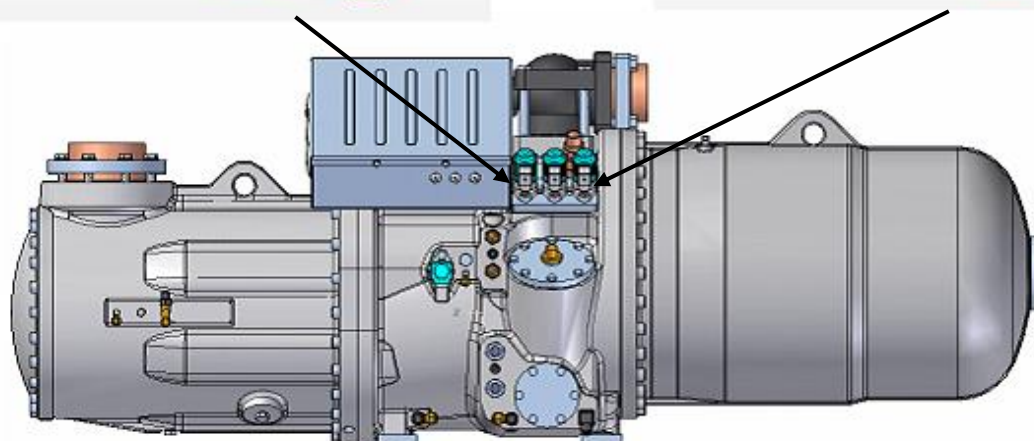
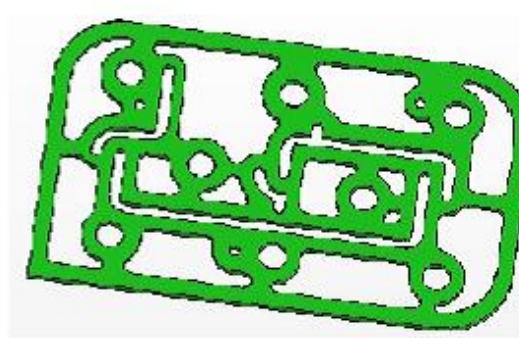

Plate LZ



To convert the compressor lay-out from the stepped "L4" to the stepless "LZ" capacity control configuration, replace the plate code 592833 with the plate code 592832. Vice-versa you will perform the opposite switch.



## 16 Extent of delivery

The standard delivery includes:

- ✓ Mineral oil charge for refrigerant HFC;
- ✓ Compressor with  $V_i = 2,6$  built-in volumetric ratio;
- ✓ Suction shut off valve;
- ✓ Discharge shut off valve;
- ✓ Integrated check valve;
- ✓ Integrated safety relief valve;
- ✓ Flanged –on oil separator;
- ✓ Oil sight glass;
- ✓ Oil filter;
- ✓ Steps or stepless capacity control;
- ✓ Electronic module INT 69 SNY (for RS3-H300/H350/H390)
- ✓ 6 thermistors integrated into the motor windings and electronic module INT 69 B2 for motor temperature monitoring;
- ✓ Crankcase heater;
- ✓ Electrical box with protection class IP54;
- ✓ 400 V  $\pm$  10% - 3 - 50 Hz / 460 V  $\pm$  10% - 3 - 60 Hz motor;
- ✓ Electrical devices 230V/1/50-60 Hz;
- ✓ Nitrogen protective charge;
- ✓ Rubber vibration dampers kit.

Available on demand:

- Electrical motors with special voltage;
- compressor with  $V_i = 2.2, 3.2$  or  $4.4$  built-in volumetric ratio;
- Electrical accessories with voltages different than the standard;
- Ester oils (POE) for the refrigerants HCFC: R22;
- Electronic module INT 69 SNY (motor and oil temperature monitoring, motor rotation direction monitoring, phase failure monitoring);
- Liquid injection connection;
- ECO connection with shut-off valve;
- kit for the connections to the external oil circuit;
- Bridges for direct starting (D.O.L.);
- Oil flow switch kit;
- Conversion kit for infinity/step capacity control.

**SRM Italy Srl**

via E. Majorana, 10/12 - 36045 Lonigo (VI) - Italy  
[www.srmtec.it](http://www.srmtec.it)

Iran, Tehran Sales Office Tel: +98 021 77 53 36 37  
[sales@srmtec.co](mailto:sales@srmtec.co)

